

HONDA

GENERAL PURPOSE ENGINE

GXV160H2

PARTS CATALOGUE

3

FOREWORD INDEX

1

ENGINE GROUP

2

PART NUMBER INDEX

3

PART NAME INDEX

4

Instruction for use of parts catalogue

- **This parts catalogue was prepared based on the latest information available as of August 01, 2020.**
- See the parts catalogue news for any revision that is made after August 01, 2020.
- **Always specify the part number when ordering a part.**
- Check the model, type, serial numbers, color, maker, and the size as needed before ordering a part.
- Note that the illustrations (part drawings) can differ from the actual parts in shape. They are given just to help you to refer to the parts.
- **When modifications or additions to this parts catalogue are made, a revised edition will be issued at an appropriate time, with successively progressing revision numbers on the cover. We recommend obtaining such revisions in order to keep your parts catalogue up-to-date at all times. To check whether a parts catalogue revision has been issued, please contact your Honda distributor.**

Initial version issue date **August 10, 2003**
Honda Motor Co., Ltd.

CONTENTS

	Page
• Instruction for use of parts catalogue	1
• How to refer to the part information	2
• Part catalogue structure.....	3
• When the parts were revised.....	4
• Abbreviations used in the parts catalogue.....	4
• How to check the part block and serial numbers.....	5
• Models, parts catalogue codes and applicable serial numbers.....	6
• Features of each type.....	8
• Fuel hose, general purpose hoses and vinyl hose.....	11
• FLAT RATE SERVICE TIME	12
• Illustrated index	17
• ENGINE GROUP	20
• PART NO. INDEX.....	66
• PART NAME INDEX.....	68



1

2

3

4

How to refer to the part information

A Reference with "Illustrated index"

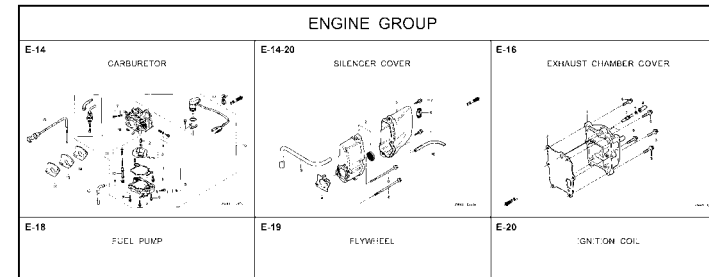

B Reference with "Part number index"

PART NO. INDEX				
Part Number	Page Ref.	Part Number	Page Ref.	Pi
06000		15212-ZW9-000	49 7	17583
		15220-ZW9-003	49 8	17583
06316-ZW9-000	104 1	15332-ZW9-000	74 2	17611
		15332-ZW9-A30	76 2	17611
11000		15400-PFB-004	46 5	17612
		15422-ZW9-000	49 9	17620
11300-ZW9-000	46 1	15473-881-000	49 10	17620
11300-ZW9-800	46 1	15474-ZW9-000	49 11	17624
11340-ZW9-000	46 2	15611-921-000	45 6	17650
11342-ZW9-000	46 3	15655-ZW9-000	46 6	17660
11381-ZW9-003	47 1			17661
12000		16000		
		16010-ZV4-005	55 1	17665
12000-ZW9-000ZA	46 4	16011-ZV4-005	55 2	17670
12155-ZV4-A00	48 1	16013-ZW9-003	55 3	17680
12166-ZW9-000	45 1	16016-ZW9-003	55 4	17701
12209-GB4-681	51 1	16016-ZW9-721	55 4	17701
12209-GB4-681	45 2	16023-ZW9-003	55 5	17701
12210-ZW9-000ZA	74 1	16024-ZV4-650	55 6	17701
12216-ZE2-300	76 1	16028-ZV4-650	55 7	17702

C Reference with "Part name index"

PART NAME INDEX			
Part name	Page	Ref.	
[A]			BOLT,
ABSORBER, FUEL	80	5	
ARMATURE COMP.	62	7	BOLT,
ARM COMP., LINK JOINT	102	18	BOLT,
ARM COMP., SHIFT LINK	102	14	BOLT,
ARM COMP., TILT	97	20	
ARM, FUEL PUMP ROCKER	51	4	
ARM, REVERSE LOCK	97	18	
ARM, SHIFT LINK	92	7	
ARM, STOPPER	52	12	BOLT,
ARM, THROTTLE REMOTE	92	6	
ARM, VALVE ROCKER	51	3	
[B]			
BAG, TOOL, 160MM	101	10	
BAND	103	37	
BAND B1, WIRE	87	1	
BAND, CORD	35	18	BOLT,
BAND, TUBE CLIP, 11MM	81	20	
BAND, TUBE CLIP, 12.5MM	81	19	BOLT.

E-2 CYLINDER HEAD

Block No.

Ref No.

Service item	F.R.T.
O-RING, 26X2.7	0.1
PLUG, SPARK	
O-RING, 9.5X1.5	0.2
SENSOR ASSY., WATER TEMPERATURE	
COVER COMP., HEAD	0.3
PACKING, HEAD COVER	
GASKET, CYLINDER HEAD	1.8
OIL SEAL, 20X32X6	2.4
HEAD COMP., CYLINDER	3.1

Ref. No.	Part No.	Description	Reqd. QTY						Serial No.	Parts catalogue code
			9901	9901	1001	1001	1001	1001		
1	12166-ZW9-000	STOPPER, ENGINE SIDE	2	2	2	2	2	2		
2	12210-ZW9-000ZA	HEAD COMP., CYLINDER	1	1	1	1	1	1		
3	12251-ZW9-003	GASKET, CYLINDER HEAD	1	1	1	1	1	1		
4	12310-ZW9-000	COVER COMP., HEAD	1	1	1	1	1	1		
5	12312-ZW9-000	PACKING, HEAD COVER	1	1	1	1	1	1		
6	15611-921-000	CAP, OIL (NO GAUGE)	1	1	1	1	1	1		
7	16617-ZW9-000	HOLDER, CABLE	1	1	1	1	1	1	SC,SG	
	16617-ZW9-010		1	1	1	1	1	1	1001800 LHC,LHD	
			1	1	1	1	1	1	1001801 LHC,LHD	
8	35673-ZV5-003	SENSOR ASSY., WATER TEMPERATURE	1	1	1	1	1	1		
9	90003-ZW9-000	BOLT, FLANGE, 6X22	6	4	4	4	4	4		
10	90007-ZW9-003	BOLT, FLANGE, 8X83	6	6	6	6	6	6		
11	90011-ZW9-000	BOLT, FLANGE, 6X14(CT200)	1	1	1	1	1	1		
12	90020-ZW9-000	BOLT, FLANGE, 6X40	2	2	2	2	2	2		
13	91202-KJ9-003	OIL SEAL, 20X32X6	1	1	1	1	1	1		
14	91301-805-000	O-RING, 26X2.7	1	1	1	1	1	1		
15	91307-PK2-005	O-RING, 9.5X1.5(HONDA KIKAKI)	1	1	1	1	1	1		
16	98059-55916	PLUG, SPARK (CR5EH-9)	2	2	2	2	2	2		
	98059-55926	PLUG, SPARK (U16FER9)	2	2	2	2	2	2		

2000.09.20 E

Page No.

Part catalogue structure

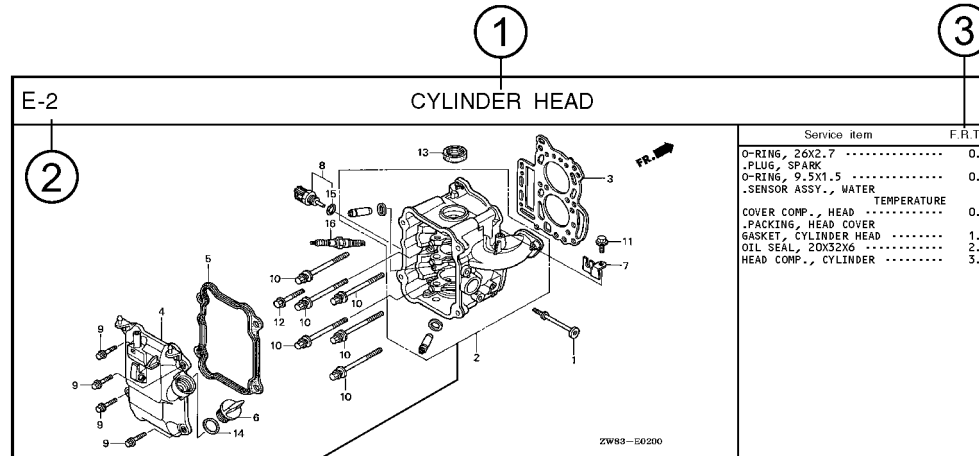

Ref. No.	Part No.	Description	Reqd. QTY						Serial No.	Parts catalogue code
			BF 9.9D1	BFP 9.9D1	BF 10D1	BFP 10D1	BF 10B1	BFP 10B1		
1	12166-zw9-000	STOPPER, ENGINE SIDE	2	2	2	2	2			
2	12210-zw9-000ZA	HEAD COMP., CYLINDER *NH8*.....DARK GRAY	1	1	1	1	1			
3	12251-zw9-003	GASKET, CYLINDER HEAD	1	1	1	1	1			
4	12310-zw9-000	COVER COMP., HEAD	1	1	1	1	1			
5	12312-zw9-000	PACKING, HEAD COVER	1	1	1	1	1			
6	15611-921-000	CAP, OIL (NO GAUGE)	1	1	1	1	1			
7	16617-zw9-000	HOLDER, CABLE	1	1	1	1	1	SC,SG		
	16617-zw9-010		1	1	1	1	1	1001800 LHC,LHD		

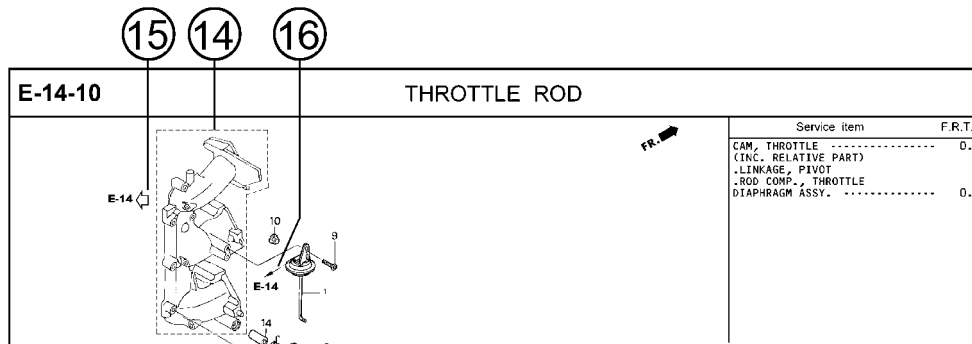

① Block title ② Block number

③ Service item/Flat rate time

④ Reference number

- Title number marked with the parenthesis or parentheses indicates that it continues from the previous page.

⑤ Part number ⑥ Honda color code

⑦ Description

⑧ Assemblies

- Sections framed with broken lines in the exploded view drawings are available as complete assemblies. (Their individual parts can also be obtained.)

⑨ Color description

⑩ Note

- Notes are shown with the parentheses in the part name column.

⑪ Required quantity

- Required QTY shown in the parenthesis or parentheses indicates the optional part.
- Required QTY marked with "N" Indicates the optional part that should be selected as needed.
- Required QTY indicates the number of the part used in the block.

⑫ Serial number

⑬ Type

- When the type column is blank, it indicates that the part is applicable to all types.
- As the type of the actual unit may differ from the "parts catalogue, type" please refer to "Models, types and applicable serial numbers" for confirmation.

⑭

- Parts enclosed within a dotted line are covered in a different block.

⑮

- A hollow arrow indicates the block No. for the parts enclosed within a dotted line.

⑯

- A solid arrow indicates the block No. the part in question is connected to.

When the parts were revised



Be sure to check the serial number!!



Ref. No.	Part No.	Description	Reqd. QTY						Serial No.
			BF 99D1	BFP 9.9D1	BF 10D1	BFP 10D1	BF 10B1	BFP 10B1	
1	12166-ZW9-000	STOPPER, ENGINE SIDE	2	2	2	2	2	2	
2	12210-ZW9-000ZA	HEAD COMP., CYLINDER *NH8*.....DARK GRAY	1	1	1	1	1	1	
3	12251-ZW9-003	GASKET, CYLINDER HEAD	1	1	1	1	1	1	
4	12310-ZW9-000	COVER COMP., HEAD	1	1	1	1	1	1	
5	12312-ZW9-000	PACKING, HEAD COVER	1	1	1	1	1	1	
6	15611-921-000	CAP, OIL (NO GAUGE)	1	1	1	1	1	1	
7	16617-ZW9-000	HOLDER, CABLE (###).....	1	1	1	1	1	1	
	16617-ZW9-010	1	1	1	1	1	1	

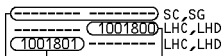

The number has been used from the initial model without revision. When shown at the left side, it is applicable to the models of No.1001801 and the subsequent numbers. When shown at the right side, it is applicable to the models up to No.1001800.

• The parts listed with "###" at the end of the parts name have limited supply period (parts not for sale).

Abbreviations used in the parts catalogue

• The following abbreviations are used in the parts name column.

- A Ampere
- A.C. Alternating current
- ASSY. Assembly
- AT. Automatic transmission
- C.D.I. Capacitive discharge ignition
- COMP. Complete
- D.C. Direct current
- EX. Exhaust
- G.F.C.I. Ground fault circuit interruptor
- HEX. Hexagonal
- H.S.T. Hydrostatic transmission
- FR. Front
- IN. Inlet
- L (100L) ... Link (100 Links)
- L. Left
- MM Millimeter
- MT. Manual Transmission
- P.T.O. Power take off
- R. Right
- RR. Rear
- STD. Standard
- T (22T) Tooth (22 Teeth)
- V Volt
- W Watt

How to check the part block and serial numbers

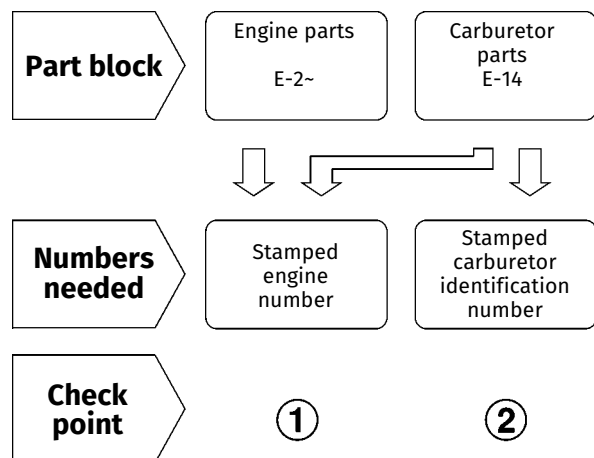

①

TYPE
ENGINE SERIAL NUMBER

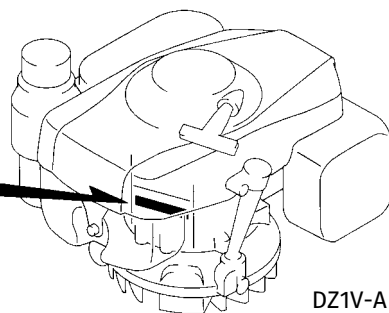

②-B

CARBURETOR IDENTIFICATION
NUMBER

②-A

CARBURETOR IDENTIFICATION
NUMBER

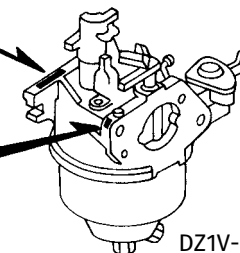

Models, parts catalogue codes and applicable serial numbers

- Models, parts catalogue codes and applicable serial Nos. given in this parts catalogue can be identified as follows.

Model	Type	Parts catalogue type	Applicable engine serial No.	Applicable carburetor identification No.	Model	Type	Parts catalogue type	Applicable engine serial No.	Applicable carburetor identification No.
GXV160H2	A14	A14	GJAAH-1000001~9999999	BE66J A	GXV160H2	N1F5	N1F5	GJAAH-1000001~3029976	BE66N A
	A1N5	A1N5	GJAAH-1000001~3029976	BE66N A			N1F5/A	GJAAH-3029977~	BEA2T A
		A1N5/A	GJAAH-3029977~	BEA2T A		N4	N4	GJAAH-1000001~9999999	BE66J A
	A1S	A1S	GJAAH-1000001~9999999	BE66J A					
	A1SA	A1SA				N4C	N4C	GJAAH-1000001~	BE66N A
	A1T5	A1T5	GJAAH-3000001~	BEA2W A					
	C12	C12	GJAAH-1000001~	BE66J A BE66N A		N4N5/A	GJAAH-3029977~		
		C14	C14			GJAAH-1000001~3029976	N5	N5	GJAAH-1000001~
	C14/A		GJAAH-3029977~	BE66N B					
	N1	N1	GJAAH-1000001~9999999	BE66J A		N55	N55	GJAAH-1000001~9999999	BE66J A
	N155	N155	GJAAH-3000001~	BEA2Y A					
	N1B5	N1B5				GJAAH-1000001~	BE66N A		
	N1F	N1F	GJAAH-1000001~9999999	BE66J A				N6W	N6W
				N6WY	N6WY	GJAAH-3000001~	BEA2T A		

Model	Type	Parts catalogue type	Applicable engine serial No.	Applicable carburetor identification No.
GXV160H2	SFC	SFC	GJAAH-1000001~	BE66J A BE66N A
	SFE	SFE	GJAAH-1000001~3029976	BE66N A
		SFE/A	GJAAH-3029977~	BEA2T A
	SFE1	SFE1	GJAAH-1000001~3029976	BE66N A
		SFE1/A	GJAAH-3029977~	BEA2T A
	SFE4	SFE4	GJAAH-1000001~9999999	BE66N A
	SFE5	SFE5	GJAAH-3000001~	BE66N B
	SFJ	SFJ	GJAAH-1000001~9999999	BE66N A
	SFL	SFL		BE66J A
	SFL1	SFL1		
	SFL5	SFL5	GJAAH-3000001~	BEA2W A
	SFN1	SFN1	GJAAH-1000001~	BE66N A
	SFNR	SFNR	GJAAH-1000001~3029976	
SFNR/A		GJAAH-3029977~	BE66N B	

Model	Type	Parts catalogue type	Applicable engine serial No.	Applicable carburetor identification No.
GXV160H2	SFY	SFY	GJAAH-1000001~9999999	BE66J A
	SFY1	SFY1		
	T1A5	T1A5	GJAAH-3000001~	BEA2W A
	T1AH	T1AH	GJAAH-1000001~9999999	BE66J A
	TBE5	TBE5	GJAAH-3000001~	BEA2W A

* Of carburetor identification numbers, only the portions underlined in the example below are used for registration.

BE 66J A KC ナ
 (A) (B)



Features of each type

• See the following table for the features of each type. (Items in brackets are optional)

Specifications		Model	GXV160H2												
		Type	A14	A1N5	A1S	A1SA	A1T5	C12	C14	N1	N15	N155	N1B5	N1F	N1F5
Crankshaft	22mm Ø Straight														
	22.2mm Ø Straight	●	●	●	●			●	●	●	●	●	●	●	
	25.4mm Ø Straight (Flat key-way)														
	25.4mm Ø Straight														
	20mm Ø Stepped thread						●								
	5/8" Stepped thread					●									
	1/5" Tapered														
	M14 Stepped thread														
Flywheel brake		●	●	●	●	●	●	●							

1

Specifications		Model	GXV160H2												
		Type	N4	N45	N4C	N4N5	N5	N55	N5M	N6	N6S	N6W	N6WY	SFC	SFE
Crankshaft	22mm Ø Straight									●		●	●		
	22.2mm Ø Straight														
	25.4mm Ø Straight (Flat key-way)	●	●	●	●										
	25.4mm Ø Straight					●	●								
	20mm Ø Stepped thread										●			●	●
	5/8" Stepped thread														
	1/5" Tapered								●						
	M14 Stepped thread														
Flywheel brake														●	



Specifications		Model	GXV160H2														
		Type	SFE1	SFE4	SFE5	SFJ	SFL	SFL1	SFL5	SFN1	SFNR	SFY	SFY1	T1A5	T1AH	TBE5	
Crankshaft	22mm Ø Straight																
	22.2mm Ø Straight																
	25.4mm Ø Straight (Flat key-way)																
	25.4mm Ø Straight																
	20mm Ø Stepped thread	●	●	●	●	●	●	●	●	●	●	●					
	5/8" Stepped thread														●		
	1/5" Tapered																
	M14 Stepped thread													●		●	
Flywheel brake																	

Fuel hose, general purpose hoses and vinyl hose

- The standard part fuel hose, general purpose hose and vinyl hose may be substituted by the coiled bulk part.
- When ordering the standard part fuel hose, general purpose hose and vinyl hose use the bulk part number written in the parts catalog in brackets () underneath the part name.
- When exchanging the hose, cut and use at the specified length as mentioned in the part name.
(For the method of cutting the bulk part, and method of filling out orders etc., please refer to the instructions issued with the bulk part.)

Bulk part number of fuel hose, general purpose hose and vinyl hose.

Example: 9 5 0 0 1 - 7 5 0 0 1 - 5 0 M

Bulk part number:

Refers to the bulk part.

Marking code (fuel hose and general purpose hose)

Change code (Vinyl hose)

Indicates number mark or change sequence, however, the code for the bulk part must be strictly 0 (zero).

Types of code:

- | | | | | | |
|-------------|--|----------------|--|--------------|---|
| • Fuel hose | 2: Red outside braid
(3 mm inside dia. only) | • General hose | 1: Ash gray
2: Ash gray
3: Black
5: Black | • Vinyl hose | 1: Clear
2: Black
3: Light red
6: Light red
7: Pale black |
| | 5: Black inside braid | | | | |
| | 3: Red (3 mm inside dia. only) | | | | |
| | 4: Ash gray with red stripe
(3 mm inside dia. only) | | | | |
| | 6: Black | | | | |

Lengths:

- 001: 1 m (standard)
003: 3 m
008: 8 m } Application or specification of some parts is not settled.

I.D code: (fuel hose and general purpose hose)

- | | | | | |
|------------|--------------------|--------------------|-----------------------------|-----------------------------|
| 30: 3.0 mm | 50: 5.0 mm | 70: 7.0 mm | 11: 11 mm | 12: 12 (outside dia. 17) mm |
| 35: 3.5 mm | 55: 5.3 mm, 5.5 mm | 75: 7.3 mm, 7.5 mm | 91: 12 (outside dia. 15) mm | 14: 14 mm |
| 45: 4.5 mm | 65: 6.5 mm | 80: 8.0 mm | 92: 12 (outside dia. 16) mm | 17: 17 mm |

ID./OD. code: (vinyl hose)

- | | | | | |
|-------------------------|--------------------------|---------------------------|---------------------------|---------------------------|
| 01: ID. 2.9, OD. 6.8 mm | 12: ID. 5.0, OD. 7.0 mm | 21: ID. 8.0, OD. 9.0 mm | 37: ID. 11.0, OD. 15.0 mm | 50: ID. 16.0, OD. 19.0 mm |
| 03: ID. 3.0, OD. 6.0 mm | 10: ID. 5.0, OD. 8.0 mm | 23: ID. 8.0, OD. 12.0 mm | 38: ID. 12.0, OD. 13.0 mm | 55: ID. 17.5, OD. 20.5 mm |
| 05: ID. 3.5, OD. 6.5 mm | 11: ID. 5.0, OD. 9.0 mm | 25: ID. 9.0, OD. 11.0 mm | 39: ID. 12.0, OD. 14.0 mm | 60: ID. 22.0, OD. 27.0 mm |
| 07: ID. 4.0, OD. 7.0 mm | 14: ID. 6.0, OD. 9.0 mm | 27: ID. 9.0, OD. 13.0 mm | 40: ID. 12.0, OD. 16.0 mm | |
| 08: ID. 4.5, OD. 6.5 mm | 17: ID. 7.0, OD. 9.0 mm | 33: ID. 10.0, OD. 14.0 mm | 43: ID. 13.0, OD. 15.0 mm | |
| 09: ID. 4.5, OD. 8.0 mm | 19: ID. 7.0, OD. 11.0 mm | 36: ID. 11.0, OD. 13.0 mm | 45: ID. 14.0, OD. 18.0 mm | |

Hose type:

- 1: Fuel hose
3: Vinyl hose
5: General hose

⊙ **CAUTION: It is DANGEROUS to confuse the fuel hose with the general purpose hose or vinyl hose.**

Never use a general purpose hose or vinyl hose in place of a fuel hose or vice versa. Always use the correct bulk part in the parts catalogue, according to the service manual or the instructions issued with the bulk part.



FLAT RATE SERVICE TIME

Flat rate service time (FRT) means the standard time required to service a product, which is listed in this manual to help the dealers control the actual working process and calculate the service charge by using it as a guide.

FRT setting system

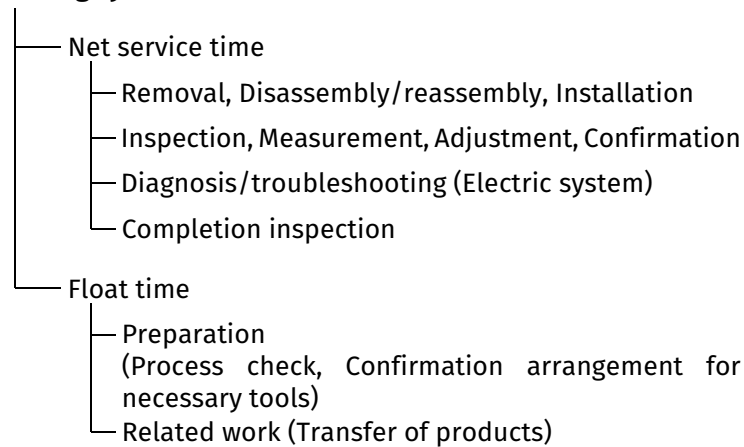

* Float time is set by multiplying the net service time by a given coefficient.

Editorial style

The service items shown in the text are listed with the exchange work time for the repair sales parts as the subject. Other representative service items not using repair parts (removal/installation, adjustment, inspection/measuring, and other work) are listed collectively in the list in the preface, classified according to the work.

FRT setting standard

- Decimal system (in unit of 0.1) is adopted to set FRT as it is convenient to calculate the wage.
Example: (0.1)→6 minutes, (0.2)→12 minutes
[Labor cost per hour] x [FRT] = [Wage]
- FRT is set with a hand tool.
- Service items and FRT can be subject to change depending on development of tools and service equipment and improvement in service procedure.

Work procedure

- As the work procedure is set with the work time according to the method in the separate Service Manual, refer to this Manual as required.
- Work methods permitting servicing in the shortest time still permitting assurance of safe work and product warranty are used for the setting of service items not listed in the Service Manual.
- Work basically is to be performed by one person, and when two or more people are required, setting is done as the total time for the number of people.
- The set value for the technological level of the workers uses a person with three years of experience in the repair of Honda products as the standard.
- Special tools and service equipment used to set FRT are those specified or recommended in Service Manual.

Service item whose FRT is not presented

- Accessories and service parts that are not listed to use in this manual.
 - Locations with little aging deterioration or breakage during normal use.
 - Service work that can be finished by one touch.
 - Service work that is seldom done (i.e. extremely small causes of trouble and service frequency).
 - Products and parts whose location for installation differs according to its status of use and application.
- * When FRT is not presented, please calculate wages based on appropriate actual work time.

Operation not included of FRT

- Oil and coolant water draining, Waiting time for warming up operation and etc..
- Additional operation that involves removal/installation of standard exterior equipment.
- Indirect time spent for service by visiting the customer, trade-in, and delivery.
- Indirect time required for ordering and delivery of parts.
- Cost for grease, adhesive agent, etc. used for service work.

**Explanation of FRT by using an example
(The example may differ from the actual presented items)**

Ref. No.	L.O.N.	(Relative ref. Number) Description	F.R.T.
①	1111L1	(1, 3, 4, 7) VALVE, INTAKE 4.1	②
③	1111L1A	• NOTE: OHV type • Includes: Engine removal and installation	⑦
		One head (intake all) add1.4	⑤

- ① Reference No. of the illustration of part that shows location of the replacement work.
- ② FRT is an abbreviation of Flat Rate Time indicating the standard service time required for the replacement.
- ③ LON is an abbreviation of Labor Operation Number, and it is a classification of the service items by the work unit code.

The same operation code is used regardless of the models.

Standard operation is indicated with 6 digits code, and additional operation is indicated with 7 digits code.

- ④ Indicating the intake valve replacement and FRT4.1.
- ⑤ Indicating FRT1.4 that will be added when additional operation (whole intake side of one cylinder head) is done in association with intake valve replacement.

- ⑥ Indicating work condition or application condition of the service item.
- ⑦ Indicating work contents that are included in the service item.
- ⑧ Indicating a reference No. whose operation and time are the same as FRT4.1 for the intake valve.

(The application range is limited to the service items without an LON setting within a same block.)

**How to refer to the service item by using the sample
(intake valve replacement)**

Open to the page of the block where the intake valve's spare part illustration is shown.

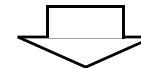

Look for the intake valve illustration, and refer to the service item and FRT that agree with the reference No.

Indication mark for the listing of service items that continues to the following page

Ref. No.	L.O.N.	(Relative ref. Number) Description	F.R.T.
2	1111L1	VALVE, INTAKE	4.1
	.	.	.
	.	.	.

+
Mark indicated at the last line.

Indication of the block with no setting of FRT

Ref. No.	L.O.N.	(Relative ref. Number) Description	F.R.T.
NO INFORMATION			

• **LON code system**

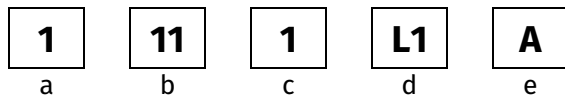

- a) Category code..... Engine
- b) Location/function code..... Engine upper
- c) Operation code..... Replace
- d) Operation sequence number (Unit code can be shown with alphabet)
..... Intake valve
(No regular rule of code)
- e) Additional code..... One head (intake all)
(No regular rule of code)

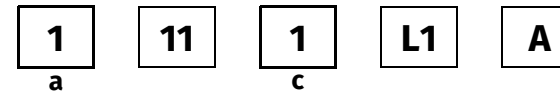

a) Category codes and classification

Code	Category
1	Engine
2	Power drive
3	Fuel & Exhaust
4	Frame & Body
5	Steering
6	Electrical
7	Axle & Brake
8	Control system
9	-
0	Attachments

c) Operation codes and classification

Code	Operation category
1	Replace, Removal/Installation, Change
2	Overhaul
3	Adjust, Rotation
4	(Paint-related work: Top-coat)
5	Test, Inspect/diagnose, Measurement
6	(Overhaul-related work: Rebore)
7	(Overhaul-related work: Reseal)
8	(Resurface)
9	(Paint-related work: Refinish)
0	Repair, Cleaning, Air bleeding



Major service items without using spare parts

Removal/Installation, Adjustment, Inspection/Measurement, Overhaul, Other work

E: Engine, T: Transmission, D: Drive system, B: Body and related parts

• Removal/Installation

Set with the parts configuration in the status of being removed from the product.

• Adjustment

	LON	DESCRIPTION	FRT
E	1113A1	VALVE CLEARANCE-ADJUSTMENT NOTE: For 1 product	0.4
	1163A0	CONTROL, THROTTLE/GOVERNOR-ADJUSTMENT	0.2
	3113A2	CARBURETOR IDLE-ADJUSTMENT	0.2

• Inspection/Measurement

	LON	DESCRIPTION	FRT
E	1105A0	ENGINE OIL-INSPECTION	0.1

• Overhaul

Work conditions: The required measurements, inspections, adjustments, and cleaning/washing for each part are performed, including the main body removal/installation work and the replacement of defective parts.

	LON	DESCRIPTION	FRT
E	3112A0	CARBURETOR-OVERHAUL INCLUDES: All necessary adjustment	0.6

• Other work

	LON	DESCRIPTION	FRT
E	1101E1	ENGINE OIL-CHANGE INCLUDES: Engine oil-inspection	0.1
	3120A0	AIR CLEANER-CLEANING INCLUDES: Air cleaner-inspection	0.2
	3130A0	SPARK ARRESTER-CLEANING INCLUDES: Spark arrester-inspection	0.2
	6140A0	SPARK PLUG-ADJUSTMENT/CLEANING INCLUDES: Spark plug check NOTE: For 1 product	0.2

ENGINE GROUP

E-2

CYLINDER HEAD

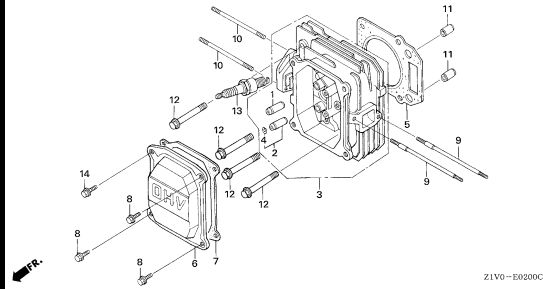

E-3

CYLINDER BARREL

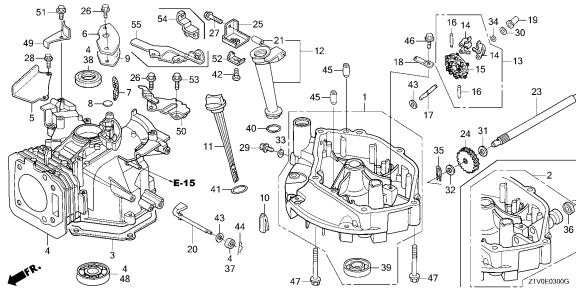

E-7

CRANKSHAFT/PISTON

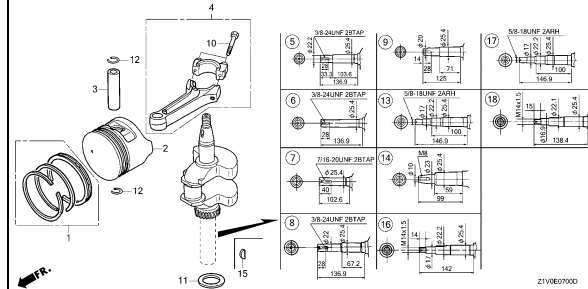

E-9

CAMSHAFT

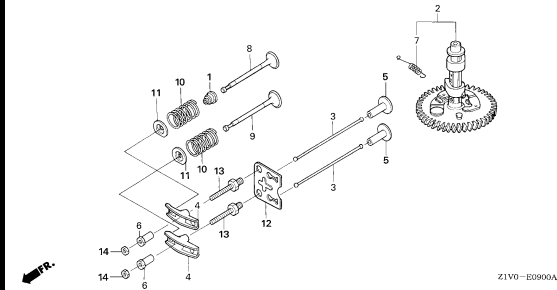

E-11

RECOIL STARTER(1)

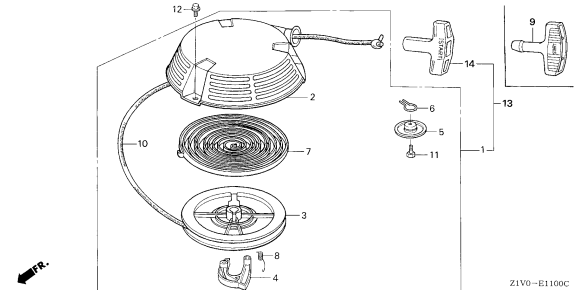

E-11-1

RECOIL STARTER(2)

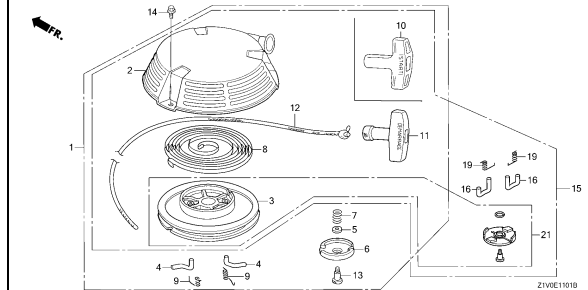

E-11-2

RECOIL STARTER(3)

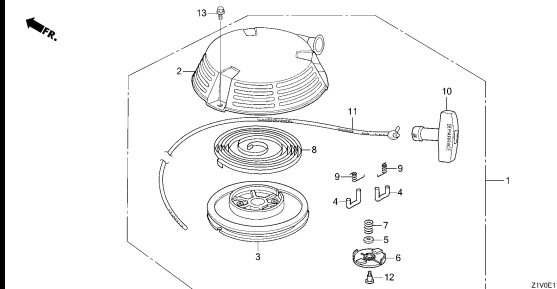

E-12

FAN COVER(1)

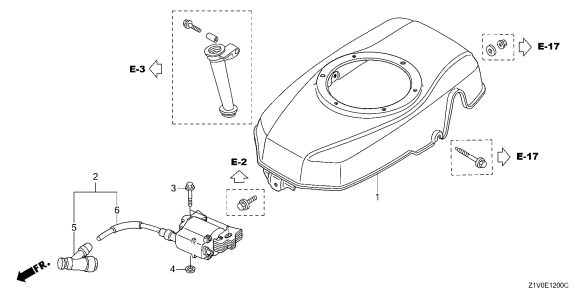

E-12-1

FAN COVER(2)

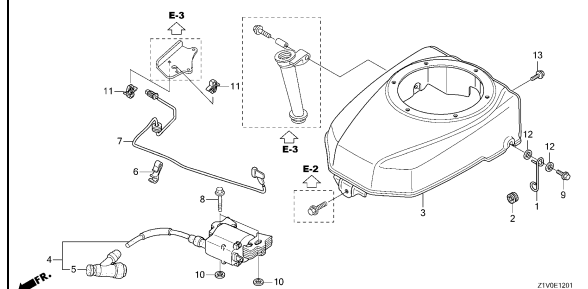

2

ENGINE GROUP

E-14

CARBURETOR

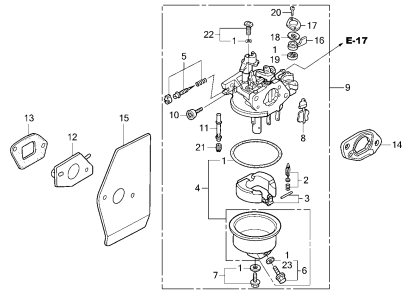

Z1V0E1800C

E-15

AIR CLEANER

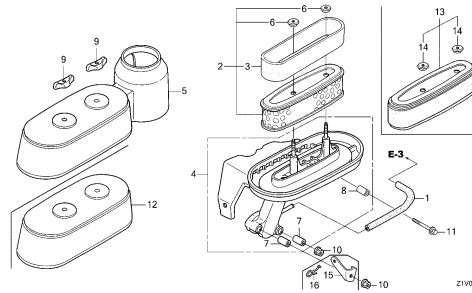

Z1V0E1900F

E-16

MUFFLER

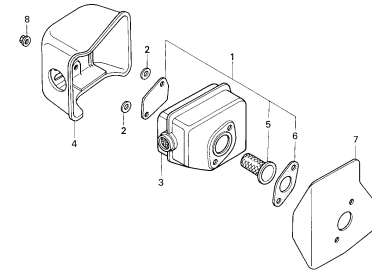

Z1V0-E1600

E-17

FUEL TANK

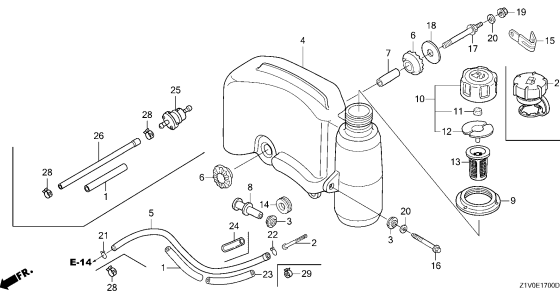

Z1V0E1700D

E-19

FLYWHEEL(1)

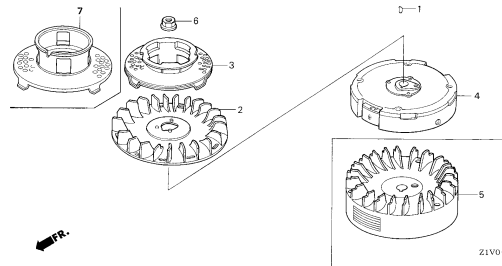

Z1V0-E1900A

E-19-1

FLYWHEEL(2)

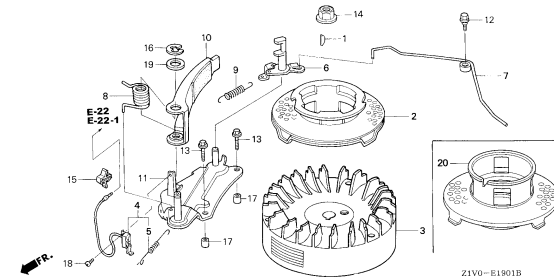

Z1V0-E1901B

E-22

CONTROL(1)

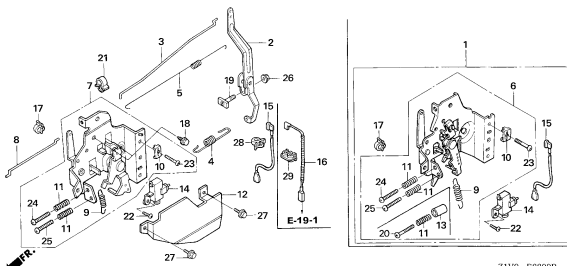

Z1V0-E2200B

E-22-1

CONTROL(2)

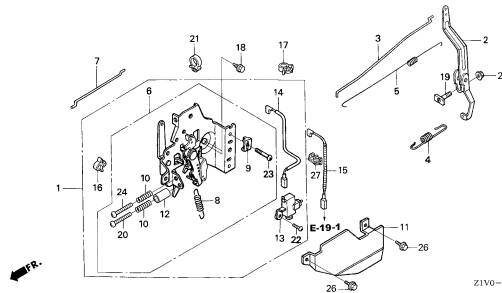

Z1V0-E2201B

E-22-2

CONTROL(3)

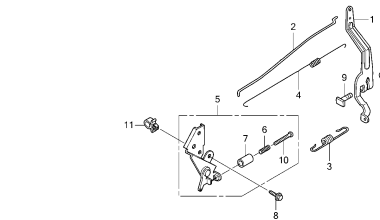

Z1V0E2202

2

ENGINE GROUP

E-28

LABEL/TOOL(1)

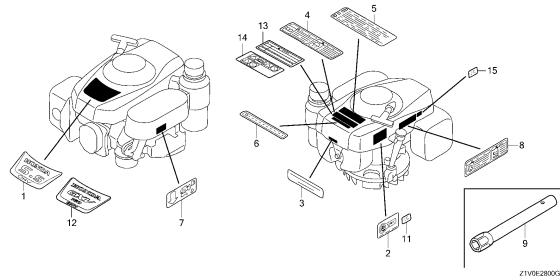

Z1V0E2800G

E-28-1

LABEL/TOOL(2)

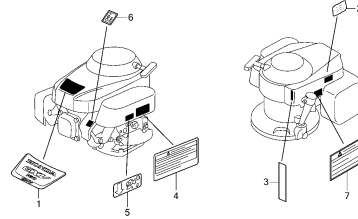

Z1V0E2801

E-40

BLADE HOLDER

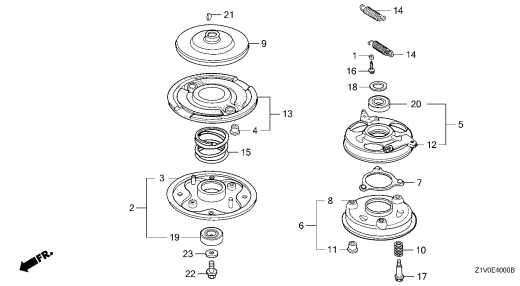

Z1V0E4000B

E-40-1

OTHER PARTS

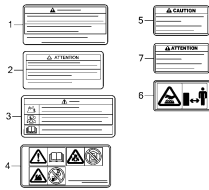

Z1V0E4001

2

E-2

CYLINDER HEAD

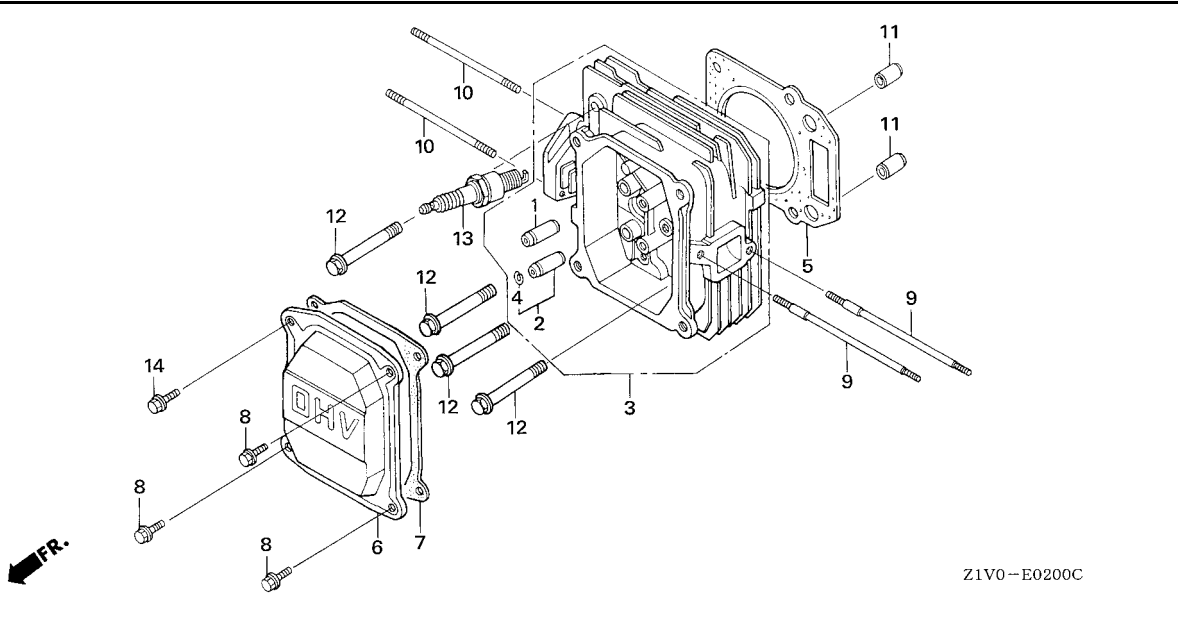

Ref. No.	L.O.N.	(Relative ref. Number) Description	F.R.T.
1	1111E9	GUIDE, INTAKE VALVEINCLUDES: Valve clearance adjustment	0.8
	1111E9E	.Replace intake and exhaust all add	0.2
2	1111E8	GUIDE, EXHAUST VALVEINCLUDES: Valve clearance adjustment	0.8
	1111E8E	.Replace intake and exhaust all add	0.2
3	1111N3	HEAD, CYLINDER	1.0
5	1111N4	GASKET, CYLINDER HEAD	0.6
6	1111D5	CYLINDER HEAD COVER AND/OR PACKING	0.1
13	6141C1	PLUG, SPARK	0.1
		.INCLUDES: Spark plug check	

Z1V0-E0200C

Ref. No.	Part No.	Description	Reqd. QTY	Serial No.	Parts catalogue code
			GXV 160 H2		
1	12204-ZE1-306	GUIDE, IN. VALVE(O.S.)	1		
2	12205-ZE1-315	GUIDE, EX. VALVE(O.S.)	1		
3	12200-ZE7-405	HEAD COMP., CYLINDER	1		
4	12216-ZE5-300	CLIP, VALVE GUIDE	1		
5	12251-ZE7-000	GASKET, CYLINDER HEAD	1		A14, A1S, A1SA, N1, N15, N1F, N4, N45, N55, N5M, SFL, SFL1, SFY, SFY1, T1AH
	12251-Z1V-701	GASKET, CYLINDER HEAD (NINGBO SIL GASKET)	1		A1N5, A1N5/A, A1T5, C12, C14, C14/A, N155, N1B5, N1F5, N1F5/A, N4C, N4N5, N4N5/A, N5N6, N6W, N6WY, SFC, SFE, SFE/A, SFE1, SFE1/A, SFE4, SFE5, SFJ, SFL5, SFN1, SFNR, SFNR/A, T1A5, TBE5
	12251-Z1V-003	GASKET, CYLINDER HEAD (GUANGZHOU LEAKLESS)	1		A1N5, A1N5/A, A1T5, C14/A, N155, N1B5, N1F5, N1F5/A, N4N5, N4N5/A, N6WY, SFE, SFE/A, SFE1, SFE1/A, SFE4, SFE5, SFJ, SFL5, SFN1, SFNR, SFNR/A, T1A5, TBE5
	12251-ZE7-000	GASKET, CYLINDER HEAD	1	1453288	C12, C14, N4C, N5, N6, N6S, N6W, SFC
	12251-Z1V-003	GASKET, CYLINDER HEAD (GUANGZHOU LEAKLESS)	1	1453289	C12, C14, N4C, N5, N6, N6S, N6W, SFC
6	12311-ZG9-800	COVER, HEAD	1		A14, A1N5, A1N5/A, A1S, A1SA, A1T5, N1, N15, N155, N1B5, N1F, N1F5, N1F5/A, N4, N45, N4N5, N4N5/A, N5, N55, N5M, N6, N6S, N6W, N6WY, SFE, SFE/A, SFE1, SFE1/A, SFE4, SFE5, SFJ, SFL, SFL1, SFL5, SFN1, SFNR, SFNR/A, SFY, SFY1, T1A5, T1AH, TBE5
	12310-Z1V-S40	COVER COMP., HEAD	1		C12, C14, C14/A, N4C, SFC
7	12391-ZE7-M10	PACKING, HEAD COVER	1		
	12312-Z1V-701	PACKING, HEAD COVER (NINGBO SIL GASKET)	1		A1N5, A1N5/A, A1T5, C12, C14, C14/A, N155, N1B5, N1F5, N1F5/A, N4C, N4N5, N4N5/A, N5N6, N6W, N6WY, SFC, SFE, SFE/A, SFE1, SFE1/A, SFE4, SFE5, SFJ, SFL5, SFN1, SFNR, SFNR/A, T1A5, TBE5
8	90013-883-000	BOLT, FLANGE, 6X12(CT200)	3		A14, A1S, A1SA, N1, N15, N1F, N4, N45, N55, N5M, SFL, SFL1, SFY, SFY1, T1AH
	90014-952-000	BOLT, FLANGE, 6X14(CT200)	3		A1N5, A1N5/A, A1T5, C14/A, N155, N1B5, N1F5, N1F5/A, N4N5, N4N5/A, N6W, N6WY, SFE, SFE/A, SFE1, SFE1/A, SFE4, SFE5, SFJ, SFL5, SFN1, SFNR, SFNR/A, T1A5, TBE5
	90013-883-000	BOLT, FLANGE, 6X12(CT200)	3	1206437	C12, C14, N4C, N5, N6, N6S, SFC

E-2

CYLINDER HEAD

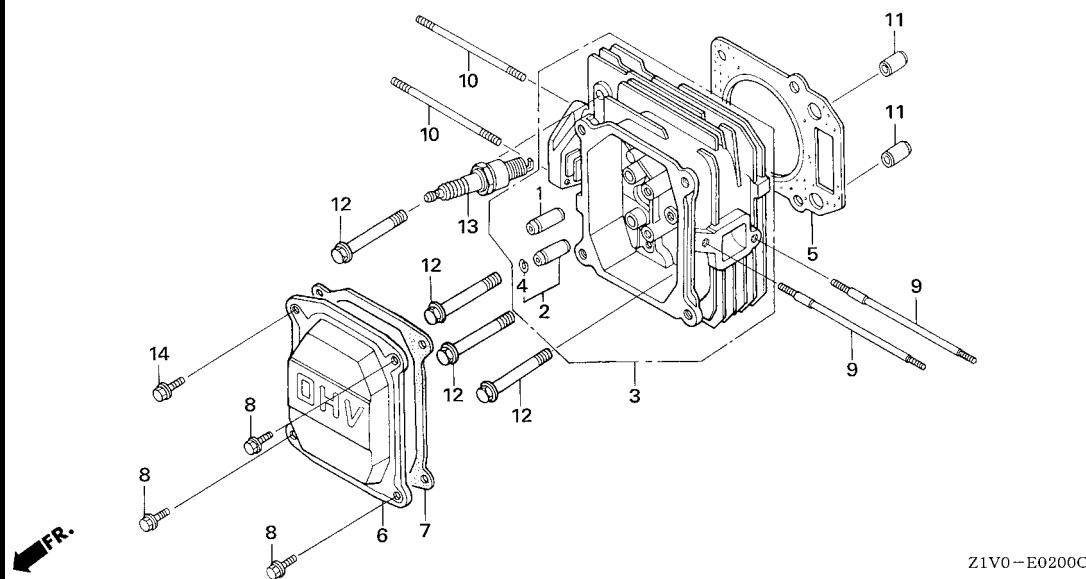

Ref. No.	Part No.	Description	Reqd. QTY		Serial No.	Parts catalogue code
			GXV 160 H2			
(8)	90014-952-000	BOLT, FLANGE, 6X14(CT200)	3	1206438	-----	C12, C14, N4C, N5, N6, N6S, SFC
9	90043-ZE6-000	BOLT, STUD, 6X109	2	-----	-----	A14, A1S, A1SA, N1, N15, N1F, N4, N45, N55, N5M, N6S, SFL, SFL1, SFY, SFY1, T1AH
	90043-Z1V-000	BOLT, STUD, 6X97	2	-----	-----	A1N5/A, A1T5, C14/A, N155, N1B5, N1F5/A, N4N5/A, N6WY, SFE/A, SFE1/A, SFE5, SFL5 SFNR/A, T1A5, TBE5
	90043-ZE6-000	BOLT, STUD, 6X109	2	-----	2571538	A1N5, C12, C14, N1F5, N4C, N4N5, N5, N6, N6W, SFC, SFE, SFE1, SFE4, SFJ, SFN1, SFNR
	90043-Z1V-000	BOLT, STUD, 6X97	2	2571539	-----	A1N5, C12, C14, N1F5, N4C, N4N5, N5, N6, N6W, SFC, SFE, SFE1, SFE4, SFJ, SFN1, SFNR
10	90048-ZC3-000	BOLT, STUD, 6X85	2	-----	-----	A14, A1S, A1SA, N1, N15, N1F, N4, N45, N55, N5M, N6S, SFL, SFL1, SFY, SFY1, T1AH
	90048-Z1V-000	2	-----	-----	A1N5/A, A1T5, C14/A, N155, N1B5, N1F5/A, N4N5/A, N6WY, SFE/A, SFE1/A, SFE5, SFL5 SFNR/A, T1A5, TBE5
	90048-ZC3-000	2	-----	2571538	A1N5, C12, C14, N1F5, N4C, N4N5, N5, N6, N6W, SFC, SFE, SFE1, SFE4, SFJ, SFN1, SFNR
	90048-Z1V-000	2	2571539	-----	A1N5, C12, C14, N1F5, N4C, N4N5, N5, N6, N6W, SFC, SFE, SFE1, SFE4, SFJ, SFN1, SFNR
11	94301-10160	DOWEL PIN, 10X16	2	-----	-----	A14, A1N5, A1N5/A, A1S, A1SA, A1T5, C12, C14, C14/A, N1, N15, N155, N1B5, N1F, N1F5 N1F5/A, N4, N45, N4C, N4N5, N4N5/A, N5, N55, N5M, N6, N6S, N6W, N6WY, SFC, SFE, SFE/A SFE1, SFE1/A, SFE4, SFE5, SFL, SFL1, SFL5, SFN1, SFNR, SFNR/A, SFY, SFY1, T1A5, T1AH TBE5
12	95701-08050-00	BOLT, FLANGE, 8X50	4	-----	-----	A14, A1N5, A1N5/A, A1S, A1SA, A1T5, C12, C14, C14/A, N1, N15, N155, N1B5, N1F, N1F5 N1F5/A, N4, N45, N4C, N4N5, N4N5/A, N5, N55, N5M, N6, N6S, N6W, N6WY, SFC, SFE, SFE/A SFE1, SFE1/A, SFE4, SFE5, SFL, SFL1, SFL5, SFN1, SFNR, SFNR/A, SFY, SFY1, T1A5, T1AH TBE5
13	98079-55846	PLUG, SPARK(BPR5ES)(NGK)	1	-----	-----	A14, A1N5, A1N5/A, A1S, A1SA, A1T5, C12, C14, C14/A, N1, N15, N155, N1B5, N1F, N1F5 N1F5/A, N4, N45, N4C, N4N5, N4N5/A, N5, N55, N5M, N6, N6S, N6W, N6WY, SFC, SFE, SFE/A SFE1, SFE1/A, SFE4, SFE5, SFL, SFL1, SFL5, SFN1, SFNR, SFNR/A, SFY, SFY1, T1A5, T1AH TBE5
	98079-55855	PLUG, SPARK(W16EPR-U)(DENSO) .	1	-----	-----	A14, A1N5, A1N5/A, A1S, A1SA, A1T5, C12, C14, C14/A, N1, N15, N155, N1B5, N1F, N1F5 N1F5/A, N4, N45, N4C, N4N5, N4N5/A, N5, N55, N5M, N6, N6S, N6W, N6WY, SFC, SFE, SFE/A SFE1, SFE1/A, SFE4, SFE5, SFL, SFL1, SFL5, SFN1, SFNR, SFNR/A, SFY, SFY1, T1A5, T1AH TBE5
	98079-56846	PLUG, SPARK(BPR6ES)(NGK)	(1)	-----	-----	A14, A1N5, A1N5/A, A1S, A1SA, A1T5, C12, C14, C14/A, N1, N15, N155, N1B5, N1F, N1F5 N1F5/A, N4, N45, N4C, N4N5, N4N5/A, N5, N55, N5M, N6, N6S, N6W, N6WY, SFC, SFE, SFE/A SFE1, SFE1/A, SFE4, SFE5, SFL, SFL1, SFL5, SFN1, SFNR, SFNR/A, SFY, SFY1, T1A5, T1AH TBE5
	98079-56855	PLUG, SPARK(W20EPR-U)(DENSO) .	(1)	-----	-----	A14, A1N5, A1N5/A, A1S, A1SA, A1T5, C12, C14, C14/A, N1, N15, N155, N1B5, N1F, N1F5 N1F5/A, N4, N45, N4C, N4N5, N4N5/A, N5, N55, N5M, N6, N6S, N6W, N6WY, SFC, SFE, SFE/A SFE1, SFE1/A, SFE4, SFE5, SFL, SFL1, SFL5, SFN1, SFNR, SFNR/A, SFY, SFY1, T1A5, T1AH TBE5
	98079-54846	PLUG, SPARK(BPR4ES)(NGK)	(1)	-----	-----	A14, A1N5, A1N5/A, A1S, A1SA, A1T5, C12, C14, C14/A, N1, N15, N155, N1B5, N1F, N1F5 N1F5/A, N4, N45, N4C, N4N5, N4N5/A, N5, N55, N5M, N6, N6S, N6W, N6WY, SFC, SFE, SFE/A SFE1, SFE1/A, SFE4, SFE5, SFL, SFL1, SFL5, SFN1, SFNR, SFNR/A, SFY, SFY1, T1A5, T1AH TBE5
14	90014-952-000	BOLT, FLANGE, 6X14(CT200)	1	-----	-----	A14, A1N5, A1N5/A, A1S, A1SA, A1T5, C12, C14, C14/A, N1, N15, N155, N1B5, N1F, N1F5 N1F5/A, N4, N45, N4C, N4N5, N4N5/A, N5, N55, N5M, N6, N6S, N6W, N6WY, SFC, SFE, SFE/A SFE1, SFE1/A, SFE4, SFE5, SFL, SFL1, SFL5, SFN1, SFNR, SFNR/A, SFY, SFY1, T1A5, T1AH TBE5



E-3

CYLINDER BARREL

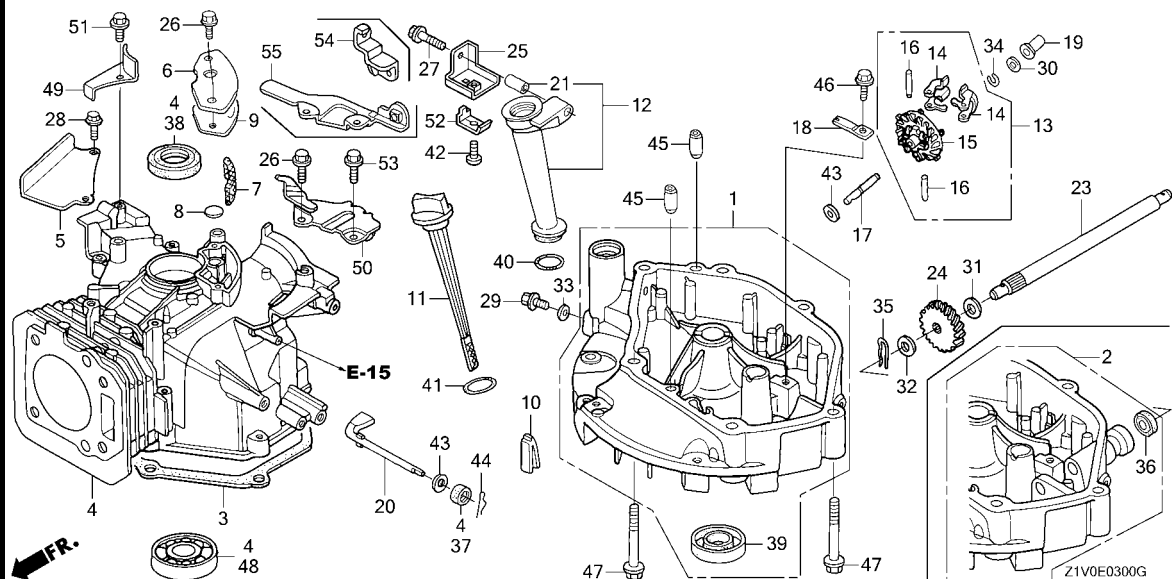

Ref. No.	L.O.N.	(Relative ref. Number) Description	F.R.T.
1		(2,3)	
1131A9		OIL PAN AND/OR PACKING	0.3
4	1101A0	BARREL, CYLINDER	1.5
7		(9)	
1111E5		FILTER, BREATHER	0.2
12		(40)	
1101B9		OIL FILLER EXTENSION AND/OR PACKING	0.1
15		(14)	
1161A7		HOLDER, GOVERNOR WEIGHT	0.4
20		(37)	
1161B4		SHAFT, GOVERNOR ARM	0.3
23		(36)	
2131J5		SHAFT, DRIVE	0.3
24	2131D5	GEAR, DRIVEN	0.3
38	1101E6	OIL SEAL, CRANKSHAFT :UPPER ..	1.1
39	1101E7	OIL SEAL, CRANKSHAFT :LOWER ..	0.3
48	1101J7	BEARING, CRANKSHAFT :LOWER ...	1.2

Ref. No.	Part No.	Description	Reqd. QTY	Serial No.	Parts catalogue code
			GXV 160 H2		
1	11300-Z1V-406	PAN ASSY., OIL	1	-----	A14, A1N5, A1N5/A, A1S, A1SA, A1T5, C12, C14, C14/A, N1, N15, N155, N1B5, N1F, N1F5, N1F5/A, N4, N45, N4C, N4N5, N4N5/A, N5, N55, N6, N6W, N6WY, T1A5, T1AH, TBE5
	11300-Z1V-408	1	-----	N5M
	11300-Z1V-409	1	-----	SFE, SFE/A, SFJ, SFNR, SFNR/A, SFY
2	11300-Z1V-407	PAN ASSY., OIL	1	-----	N6S, SFC, SFE1, SFE1/A, SFE4, SFE5, SFL, SFL1, SFL5, SFN1, SFY1
3	11381-ZE7-M10	PACKING, OIL PAN	1	-----	
	11381-Z1V-701	PACKING, OIL PAN (NINGBO SIL GASKET)	1	-----	A1N5, A1N5/A, A1T5, C12, C14, C14/A, N155, N1B5, N1F5, N1F5/A, N4C, N4N5, N4N5/A, N5, N6, N6W, N6WY, SFC, SFE, SFE/A, SFE1, SFE1/A, SFE4, SFE5, SFJ, SFL5, SFN1, SFNR, SFNR/A, T1A5, TBE5
4	12000-Z1V-000	BARREL ASSY., CYLINDER	1	-----	A14, A1S, A1SA
	12000-ZE7-406	(1)	-----	A14, A1S, A1SA, C12, C14, SFC
	12000-Z1V-405	1	-----	A1N5, C12, C14, SFC
	12000-Z1V-407	1	-----	A1N5/A, A1T5, C14/A
	12000-ZE7-405	(1)	-----	N1, N15, N1F, N4, N45, N5, N55, N5M, N6, N6S, SFL, SFL1, SFY, SFY1, T1AH
	12000-Z2J-000	1	-----	N1, N15, N1F, N4, N45, N55, N5M, SFL, SFL1, SFY, SFY1, T1AH
	12000-Z1V-406	1	-----	N155, N1B5, N1F5/A, N4N5/A, N6WY, SFE/A, SFE1/A, SFE5, SFL5, SFNR/A, T1A5, TBE5
	12000-Z2J-405	1	-----	N1F5, N4C, N4N5, N5, N6, N6S, N6W, SFE, SFE1, SFE4, SFJ, SFN1, SFNR
5	12125-Z1V-000	PLATE, GUIDE	1	-----	N1, N15, N155, N1B5, N1F, N1F5, N1F5/A, N4, N45, N4C, N4N5, N4N5/A, N5, N55, N5M, N6, N6S, N6W, N6WY, SFE, SFE/A, SFE1, SFE1/A, SFE4, SFE5, SFJ, SFL, SFL1, SFL5, SFN1, SFNR, SFNR/A, SFY, SFY1, T1A5, T1AH
	12125-Z1V-G00	1	-----	TBE5
6	12355-Z1V-000	COVER COMP., BREATHER	1	-----	
7	12367-883-003	FILTER, BREATHER	1	-----	
8	12372-ZE7-000	VALVE, BREATHER	1	-----	
9	12373-ZE7-000	PACKING, BREATHER COVER	1	-----	
10	15335-ZE7-000	RUBBER, OIL RETURN	1	-----	

E-3

CYLINDER BARREL

Ref. No.	Part No.	Description	Reqd. QTY	Serial No.	Parts catalogue code
11	15620-ZE6-810	GAUGE COMP., OIL LEVEL	1		
12	15630-ZE6-810	EXTENSION, OIL FILLER	1		
13	16510-ZE6-000	GOVERNOR ASSY.	1		
14	16511-ZE1-000	WEIGHT, GOVERNOR	2		
15	16512-ZE6-000	HOLDER, GOVERNOR WEIGHT	1		
16	16513-ZE1-000	PIN, GOVERNOR WEIGHT	2		
17	16515-ZE6-010	SHAFT, GOVERNOR HOLDER	1		
18	16525-ZE6-010	PLATE, GOVERNOR SHAFT HOLDER ..	1		
19	16531-Z1T-000	SLIDER, GOVERNOR	1		
20	16541-ZE7-000	SHAFT, GOVERNOR ARM	1		
21	17240-ZE6-000	COLLAR, EXTENSION	1		
23	23411-ZE7-010	SHAFT, DRIVE	1	-----	SFE1, SFE1/A, SFE4, SFE5, SFL5, SFN1
	23411-ZE7-000	1	-----	SFL, SFL1, SFY1
			1	1182612	N6S, SFC
	23411-ZE7-010	1	1182613	N6S, SFC
24	23421-ZE6-000	GEAR, DRIVEN(22T)	1	-----	N6S, SFC, SFE1, SFE1/A, SFE5, SFL, SFL1, SFL5, SFN1, SFY1
	23431-ZG9-T20	GEAR, DRIVEN(18T)	1	-----	SFE4
25	43143-Z1V-000	BASE COMP., HOLDER	1	-----	A14, A1N5, A1N5/A, A1S, A1SA, C12, C14, C14/A, SFC
26	90014-952-000	BOLT, FLANGE, 6X14(CT200)	3		
27	90017-883-000	BOLT, FLANGE, 6X32(CT200)	1		
28	90022-888-010	BOLT, FLANGE, 6X20(CT200)	2	-----	N1, N15, N155, N1B5, N1F, N1F5, N1F5/A, N4, N45, N4C, N4N5, N4N5/A, N5, N55, N5M, N6, N6S, N6W, N6WY, SFE, SFE/A, SFE1, SFE1/A, SFE4, SFE5, SFJ, SFL, SFL1, SFL5, SFN1, SFNR, SFNR/A, SFY, SFY1, T1A5, T1AH, TBE5
29	90131-ZE1-000	BOLT, DRAIN PLUG	1		
30	90451-ZE1-000	WASHER, THRUST, 6MM	1	-----	A14, A1S, A1SA, N1, N15, N1F, N4, N45, N55, N5M, N6S, SFL, SFL1, SFY, SFY1, T1AH
	90451-Z1T-000	1	-----	A1N5, A1N5/A, A1T5, C12, C14, C14/A, N155, N1B5, N1F5, N1F5/A, N4C, N4N5, N4N5/A, N5, N6, N6W, N6WY, SFC, SFE, SFE/A, SFE1, SFE1/A, SFE4, SFE5, SFJ, SFL5, SFN1, SFNR, SFNR/A, T1A5, TBE5
31	90452-166-600	WASHER, THRUST, 12MM	1	-----	N6S, SFC, SFE1, SFE1/A, SFE4, SFE5, SFL, SFL1, SFL5, SFN1, SFY1
32	90452-187-000	WASHER, 10X21	1	-----	N6S, SFC, SFE1, SFE1/A, SFE4, SFE5, SFL, SFL1, SFL5, SFN1, SFY1
33	90601-ZE1-000	WASHER, DRAIN PLUG, 10.2MM ..	1		
34	90602-ZE1-000	CLIP, GOVERNOR HOLDER	1		
35	90701-ZE6-000	PIN, LOCK, 2.0	1	-----	N6S, SFC, SFE1, SFE1/A, SFE4, SFE5, SFL, SFL1, SFL5, SFN1, SFY1
36	91205-Z1V-003	OIL SEAL, 12X20X6.5	1	-----	N6S, SFC, SFE1, SFE1/A, SFE4, SFE5, SFL, SFL1, SFL5, SFN1, SFY1
37	91231-Z1V-003	OIL SEAL, 6X11X4(ARAI)	1		
38	91251-Z1V-003	OIL SEAL, 25X38X7(ARAI)	1		
39	91252-Z1V-003	OIL SEAL, 25.4X40X7	1		
40	91301-Z1V-003	O-RING, 22.1X2.2	1		
41	91302-Z1V-003	O-RING, 25.5X3	1		
42	93500-05016-0A	SCREW, PAN, 5X16	1	-----	A14, A1N5, A1N5/A, A1S, A1SA, C12, C14, C14/A, SFC
43	94101-06800	WASHER, PLAIN, 6MM	2		
44	94251-08000	PIN, LOCK, 8MM	1		
45	94301-08140	DOWEL PIN, 8X14	2		
46	95701-06012-08	BOLT, FLANGE, 6X12	1		
47	95701-08050-00	BOLT, FLANGE, 8X50	6		
48	96100-62050-00	BEARING, RADIAL BALL, 6205 ..	1		
49	12126-Z1V-800	PLATE A, GUIDE	1	-----	A14, A1N5, A1N5/A, A1S, A1SA, A1T5, C12, C14, C14/A, SFC
	12126-Z1V-000	1	-----	N1, N15, N155, N1B5, N1F, N1F5, N1F5/A, N4, N45, N4C, N4N5, N4N5/A, N5, N55, N5M, N6, N6S, N6W, N6WY, SFE, SFE/A, SFE1, SFE1/A, SFE4, SFE5, SFJ, SFL, SFL1, SFL5, SFN1, SFNR, SFNR/A, SFY, SFY1, T1A5, T1AH, TBE5



E-3

CYLINDER BARREL

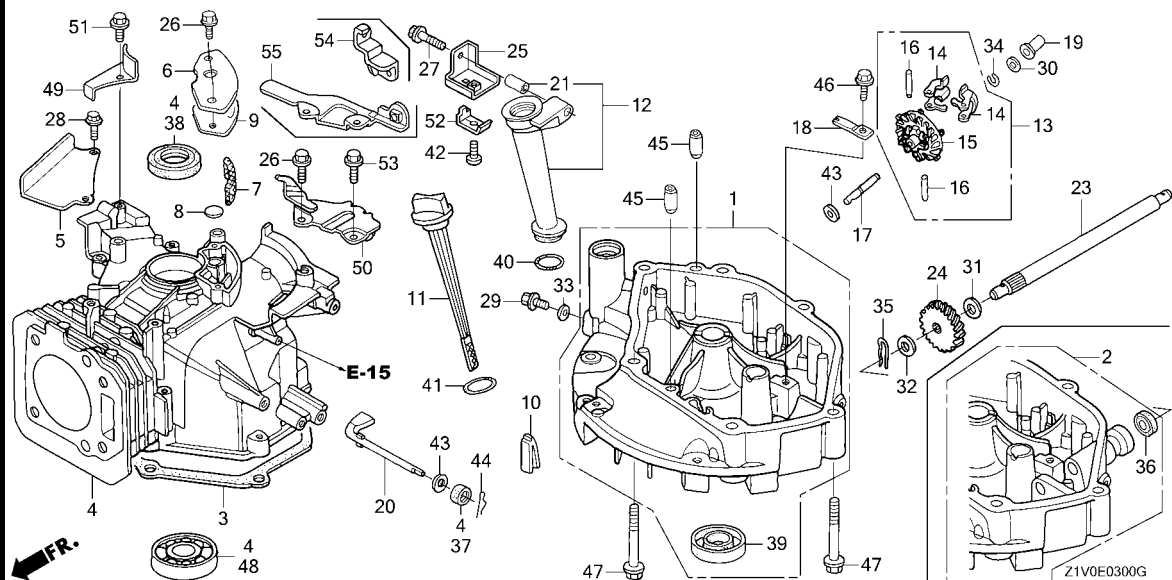

Ref. No.	Part No.	Description	Reqd. QTY		Serial No.	Parts catalogue code
			GXV	H2		
50	17560-Z1V-000	STAY COMP., TANK.....	1	-----	-----	A14, A1N5, A1N5/A, A1S, A1SA, C12, C14, C14/A, N1, N15, N155, N1B5, N1F, N1F5, N1F5/A, N4, N45, N4C, N4N5, N4N5/A, N5, N55, N5M, N6, N6S, N6W, N6WY, SFC, SFE, SFE/A, SFE1, SFE1/A, SFE4, SFE5, SFJ, SFL, SFL1, SFL5, SFN1, SFNR, SFNR/A, SFY, SFY1, T1AH
51	90013-883-000	BOLT, FLANGE, 6X12(CT200)....	1	-----	-----	A14, A1N5, A1N5/A, A1S, A1SA, C12, C14, C14/A, SFC
52	16576-891-000	HOLDER, CABLE	1	-----	-----	A14, A1N5, A1N5/A, A1S, A1SA, C12, C14, C14/A, SFC
53	90014-952-000	BOLT, FLANGE, 6X14(CT200)....	1	-----	-----	A1S, A1T5, N1, N15, N155, N1B5, N1F, N1F5, N1F5/A, N4, N45, N4C, N4N5, N4N5/A, N5, N55, N5M, N6, N6S, N6W, N6WY, SFE, SFE/A, SFE1, SFE1/A, SFE4, SFE5, SFJ, SFL, SFL1, SFL5, SFN1, SFNR, SFNR/A, SFY, SFY1, T1A5, T1AH, TBE5
54	16617-Z4P-000	HOLDER, CABLE	1	-----	-----	A1T5
55	17560-Z1V-G00	STAY COMP., FAN COVER.....	1	-----	-----	A1T5, T1A5, TBE5



E-7

CRANKSHAFT/PISTON

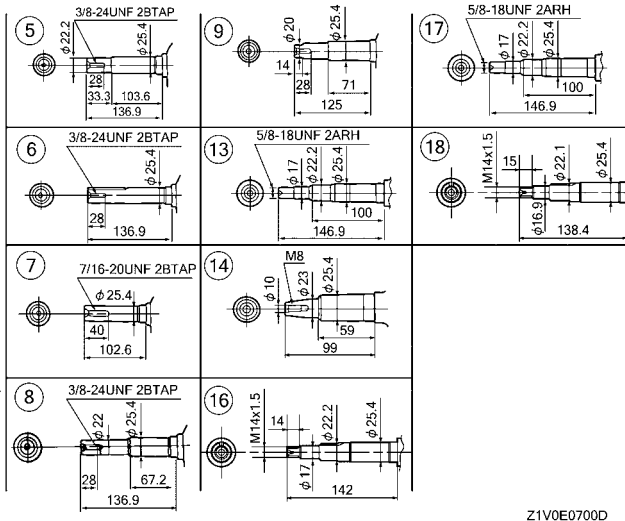
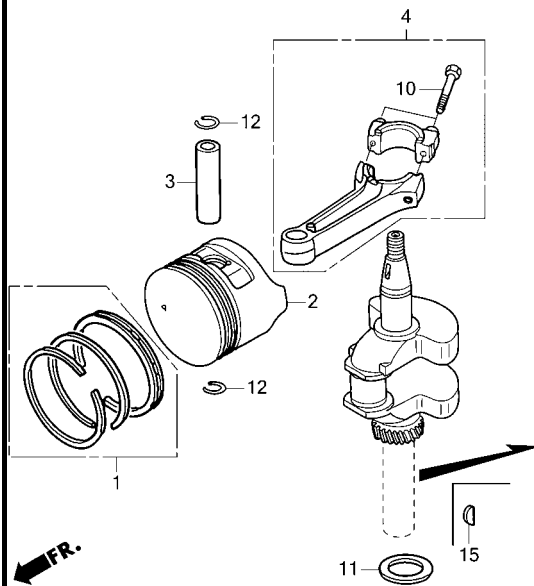

Z1V0E0700D

Ref. No.	L.O.N.	(Relative ref. Number) Description	F.R.T.
2	(1,3,4)	1111R1 PISTON AND/OR RING SET AND/OR BEARING AND/OR ROD	1.2
5	(6,7,8,9,13,14,16,17,18)	1101F0 CRANKSHAFT	1.1

Ref. No.	Part No.	Description	Reqd. QTY		Serial No.	Parts catalogue code
			GXV	H2		
1	13010-ZL0-003	RING SET, PISTON(STD.)				
	13010-ZL0-004	RING SET, PISTON(STD.) (TEIKOKU)	1		A14, A1S, A1SA, N1, N15, N1F, N4, N45, N55, N5M, SFL, SFL1, SFY, SFY1, T1AH	
	13011-ZL0-003	RING SET, PISTON(STD.) (NIPPON)	1		A14, A1S, A1SA, N1, N15, N1F, N4, N45, N55, N5M, SFL, SFL1, SFY, SFY1, T1AH	
	13011-ZL0-004	RING SET, PISTON(0.25) (TEIKOKU)	(1)		A14, A1S, A1SA, N1, N15, N1F, N4, N45, N55, N5M, SFL, SFL1, SFY, SFY1, T1AH	
	13012-ZL0-003	RING SET, PISTON(0.50) (NIPPON)	(1)		A14, A1S, A1SA, N1, N15, N1F, N4, N45, N55, N5M, SFL, SFL1, SFY, SFY1, T1AH	
	13012-ZL0-004	RING SET, PISTON(0.50) (TEIKOKU)	(1)		A14, A1S, A1SA, N1, N15, N1F, N4, N45, N55, N5M, SFL, SFL1, SFY, SFY1, T1AH	
	13013-ZL0-003	RING SET, PISTON(0.75) (NIPPON)	(1)		A14, A1S, A1SA, N1, N15, N1F, N4, N45, N55, N5M, SFL, SFL1, SFY, SFY1, T1AH	
	13013-ZL0-004	RING SET, PISTON(0.75) (TEIKOKU)	(1)		A14, A1S, A1SA, N1, N15, N1F, N4, N45, N55, N5M, SFL, SFL1, SFY, SFY1, T1AH	
	13010-Z1T-701	RING SET, PISTON(STD.) (FUJIAN DONGYA MACHINERY)	1		A1N5, C12, C14, N1F5, N4C, N4N5, N5, N6, N6W, SFC, SFE, SFE1, SFE4, SFJ, SFN1	
	13011-Z1T-701	RING SET, PISTON(0.25) (FUJIAN DONGYA MACHINERY)	(1)		A1N5, C12, C14, N1F5, N4C, N4N5, N5, N6, N6W, SFC, SFE, SFE1, SFE4, SFJ, SFN1	
	13012-Z1T-701	RING SET, PISTON(0.50) (FUJIAN DONGYA MACHINERY)	(1)		A1N5, C12, C14, N1F5, N4C, N4N5, N5, N6, N6W, SFC, SFE, SFE1, SFE4, SFJ, SFN1	
	13013-Z1T-701	RING SET, PISTON(0.75) (FUJIAN DONGYA MACHINERY)	(1)		A1N5, C12, C14, N1F5, N4C, N4N5, N5, N6, N6W, SFC, SFE, SFE1, SFE4, SFJ, SFN1	
	13010-Z4K-004	RING SET, PISTON(STD.) (TPR) ..	1		A1N5, N1F5, N4N5, SFE, SFE1, SFE4, SFNR	
	13010-Z4P-003	RING SET, PISTON(STD.) (RIKEN) ..	1		A1N5, N1F5, N4N5, SFE, SFE1, SFE4, SFNR	
	13011-Z4K-004	RING SET, PISTON(0.25) (TPR) ..	(1)		A1N5, N1F5, N4N5, SFE, SFE1, SFE4, SFNR	
	13011-Z4P-003	RING SET, PISTON(0.25) (RIKEN) ..	(1)		A1N5, N1F5, N4N5, SFE, SFE1, SFE4, SFNR	
	13012-Z4K-004	RING SET, PISTON(0.50) (TPR) ..	(1)		A1N5, N1F5, N4N5, SFE, SFE1, SFE4, SFNR	
	13012-Z4P-003	RING SET, PISTON(0.50) (RIKEN) ..	(1)		A1N5, N1F5, N4N5, SFE, SFE1, SFE4, SFNR	
	13013-Z4K-004	RING SET, PISTON(0.75) (TPR) ..	(1)		A1N5, N1F5, N4N5, SFE, SFE1, SFE4, SFNR	
	13013-Z4P-003	RING SET, PISTON(0.75) (RIKEN) ..	(1)		A1N5, N1F5, N4N5, SFE, SFE1, SFE4, SFNR	



E-7

CRANKSHAFT/PISTON

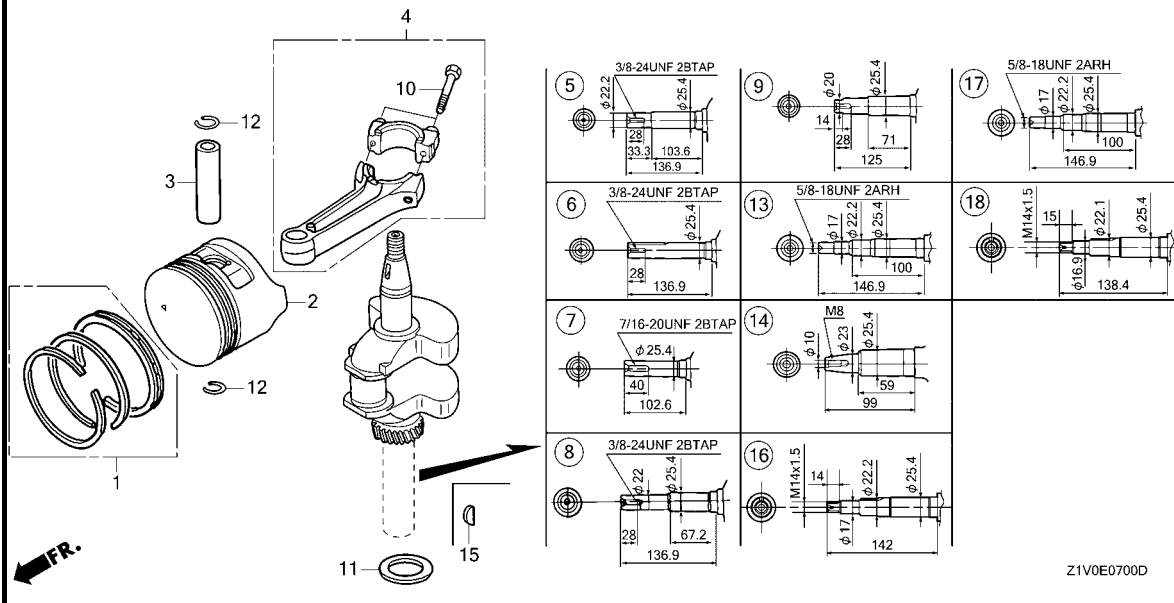

Z1V0E0700D

Ref. No.	Part No.	Description	Reqd. QTY		Serial No.	Parts catalogue code
			GXV	H2		
(1)	13010-Z1V-931	RING SET, PISTON(STD.)(TPR) ..	1	-----	-----	A1N5/A, A1T5, C14/A, N155, N1B5, N1F5/A, N4N5/A, N6WY, SFE/A, SFE1/A, SFE5, SFL5 SFNR/A, T1A5, TBE5
	13010-Z1V-932	RING SET, PISTON(STD.)(RIKEN)	1	-----	-----	A1N5/A, A1T5, C14/A, N155, N1B5, N1F5/A, N4N5/A, N6WY, SFE/A, SFE1/A, SFE5, SFL5 SFNR/A, T1A5, TBE5
	13011-Z1V-931	RING SET, PISTON(0.25)(TPR) ..	(1)	-----	-----	A1N5/A, A1T5, C14/A, N155, N1B5, N1F5/A, N4N5/A, N6WY, SFE/A, SFE1/A, SFE5, SFL5 SFNR/A, T1A5, TBE5
	13011-Z1V-932	RING SET, PISTON(0.25)(RIKEN)	(1)	-----	-----	A1N5/A, A1T5, C14/A, N155, N1B5, N1F5/A, N4N5/A, N6WY, SFE/A, SFE1/A, SFE5, SFL5 SFNR/A, T1A5, TBE5
	13012-Z1V-931	RING SET, PISTON(0.50)(TPR) ..	(1)	-----	-----	A1N5/A, A1T5, C14/A, N155, N1B5, N1F5/A, N4N5/A, N6WY, SFE/A, SFE1/A, SFE5, SFL5 SFNR/A, T1A5, TBE5
	13012-Z1V-932	RING SET, PISTON(0.50)(RIKEN)	(1)	-----	-----	A1N5/A, A1T5, C14/A, N155, N1B5, N1F5/A, N4N5/A, N6WY, SFE/A, SFE1/A, SFE5, SFL5 SFNR/A, T1A5, TBE5
	13013-Z1V-931	RING SET, PISTON(0.75)(TPR) ..	(1)	-----	-----	A1N5/A, A1T5, C14/A, N155, N1B5, N1F5/A, N4N5/A, N6WY, SFE/A, SFE1/A, SFE5, SFL5 SFNR/A, T1A5, TBE5
	13013-Z1V-932	RING SET, PISTON(0.75)(RIKEN)	(1)	-----	-----	A1N5/A, A1T5, C14/A, N155, N1B5, N1F5/A, N4N5/A, N6WY, SFE/A, SFE1/A, SFE5, SFL5 SFNR/A, T1A5, TBE5
	13010-ZL0-003	RING SET, PISTON(STD.)				
	13010-ZL0-004	RING SET, PISTON(STD.)(TEIKOKU)	1	-----	1250645	C12, C14, N4C, N5, N6, N6S, SFC
	13011-ZL0-003	RING SET, PISTON(0.25)(NIPPON)	1	-----	1250645	C12, C14, N4C, N5, N6, N6S, SFC
	13011-ZL0-004	RING SET, PISTON(0.25)(TEIKOKU)	(1)	-----	1250645	C12, C14, N4C, N5, N6, N6S, SFC
	13012-ZL0-003	RING SET, PISTON(0.50)(NIPPON)	(1)	-----	1250645	C12, C14, N4C, N5, N6, N6S, SFC
	13012-ZL0-004	RING SET, PISTON(0.50)(TEIKOKU)	(1)	-----	1250645	C12, C14, N4C, N5, N6, N6S, SFC
	13013-ZL0-003	RING SET, PISTON(0.75)(NIPPON)	(1)	-----	1250645	C12, C14, N4C, N5, N6, N6S, SFC
	13013-ZL0-004	RING SET, PISTON(0.75)(TEIKOKU)	(1)	-----	1250645	C12, C14, N4C, N5, N6, N6S, SFC
	13010-Z4K-004	RING SET, PISTON(STD.)(TPR) ..	1	-----	3080231	N6W, SFJ, SFN1

Ref. No.	Part No.	Description	Reqd. QTY		Serial No.	Parts catalogue code
			GxV 160 H2			
(1)	13011-Z4K-004	RING SET, PISTON(0.25)(TPR) ..	(1)	-----	3080231	N6W, SFJ, SFN1
	13012-Z4K-004	RING SET, PISTON(0.50)(TPR) ..	(1)	-----	3080231	N6W, SFJ, SFN1
	13013-Z4K-004	RING SET, PISTON(0.75)(TPR) ..	(1)	-----	3080231	N6W, SFJ, SFN1
	13010-Z4P-003	RING SET, PISTON(STD.)(RIKEN)	1	-----	3097157	N6W, SFJ, SFN1
	13011-Z4P-003	RING SET, PISTON(0.25)(RIKEN)	(1)	-----	3097157	N6W, SFJ, SFN1
	13012-Z4P-003	RING SET, PISTON(0.50)(RIKEN)	(1)	-----	3097157	N6W, SFJ, SFN1
	13013-Z4P-003	RING SET, PISTON(0.75)(RIKEN)	(1)	-----	3097157	N6W, SFJ, SFN1
	13010-Z4K-004	RING SET, PISTON(STD.)(TPR) ..	1	1250646	-----	C14, N6S
	13010-Z4P-003	RING SET, PISTON(STD.)(RIKEN)	1	1250646	-----	C14, N6S
	13011-Z4K-004	RING SET, PISTON(0.25)(TPR) ..	(1)	1250646	-----	C14, N6S
	13011-Z4P-003	RING SET, PISTON(0.25)(RIKEN)	(1)	1250646	-----	C14, N6S
	13012-Z4K-004	RING SET, PISTON(0.50)(TPR) ..	(1)	1250646	-----	C14, N6S
	13012-Z4P-003	RING SET, PISTON(0.50)(RIKEN)	(1)	1250646	-----	C14, N6S
	13013-Z4K-004	RING SET, PISTON(0.75)(TPR) ..	(1)	1250646	-----	C14, N6S
	13013-Z4P-003	RING SET, PISTON(0.75)(RIKEN)	(1)	1250646	-----	C14, N6S
	13010-Z4K-004	RING SET, PISTON(STD.)(TPR) ..	1	1250646	3080231	C12, N4C, N5, N6, SFC
	13011-Z4K-004	RING SET, PISTON(0.25)(TPR) ..	(1)	1250646	3080231	C12, N4C, N5, N6, SFC
	13012-Z4K-004	RING SET, PISTON(0.50)(TPR) ..	(1)	1250646	3080231	C12, N4C, N5, N6, SFC
	13013-Z4K-004	RING SET, PISTON(0.75)(TPR) ..	(1)	1250646	3080231	C12, N4C, N5, N6, SFC
	13010-Z4P-003	RING SET, PISTON(STD.)(RIKEN)	1	1250646	3097157	C12, N4C, N5, N6, SFC
	13011-Z4P-003	RING SET, PISTON(0.25)(RIKEN)	(1)	1250646	3097157	C12, N4C, N5, N6, SFC
	13012-Z4P-003	RING SET, PISTON(0.50)(RIKEN)	(1)	1250646	3097157	C12, N4C, N5, N6, SFC
	13013-Z4P-003	RING SET, PISTON(0.75)(RIKEN)	(1)	1250646	3097157	C12, N4C, N5, N6, SFC
	13010-Z1V-931	RING SET, PISTON(STD.)(TPR) ..	1	3080232	-----	C12, N4C, N5, N6, N6W, SFC, SFJ, SFN1
	13011-Z1V-931	RING SET, PISTON(0.25)(TPR) ..	(1)	3080232	-----	C12, N4C, N5, N6, N6W, SFC, SFJ, SFN1
	13012-Z1V-931	RING SET, PISTON(0.50)(TPR) ..	(1)	3080232	-----	C12, N4C, N5, N6, N6W, SFC, SFJ, SFN1
	13013-Z1V-931	RING SET, PISTON(0.75)(TPR) ..	(1)	3080232	-----	C12, N4C, N5, N6, N6W, SFC, SFJ, SFN1
	13010-Z1V-932	RING SET, PISTON(STD.)(RIKEN)	1	3097158	-----	C12, N4C, N5, N6, N6W, SFC, SFJ, SFN1
	13011-Z1V-932	RING SET, PISTON(0.25)(RIKEN)	(1)	3097158	-----	C12, N4C, N5, N6, N6W, SFC, SFJ, SFN1
	13012-Z1V-932	RING SET, PISTON(0.50)(RIKEN)	(1)	3097158	-----	C12, N4C, N5, N6, N6W, SFC, SFJ, SFN1
	13013-Z1V-932	RING SET, PISTON(0.75)(RIKEN)	(1)	3097158	-----	C12, N4C, N5, N6, N6W, SFC, SFJ, SFN1
2	13101-Z1T-000	PISTON(STD.)	1	-----	-----	A14, A1S, A1SA, N1, N15, N1F, N4, N45, N55, N5M, SFL, SFL1, SFY, SFY1, T1AH
	13101-ZH8-010	1	-----	-----	A14, A1S, A1SA, N1, N15, N1F, N4, N45, N55, N5M, SFL, SFL1, SFY, SFY1, T1AH
	13102-ZE7-020	PISTON(0.25)	(1)	-----	-----	A14, A1S, A1SA, N1, N15, N1F, N4, N45, N55, N5M, SFL, SFL1, SFY, SFY1, T1AH
	13103-ZE7-020	PISTON(0.50)	(1)	-----	-----	A14, A1S, A1SA, N1, N15, N1F, N4, N45, N55, N5M, SFL, SFL1, SFY, SFY1, T1AH
	13104-ZE7-020	PISTON(0.75)	(1)	-----	-----	A14, A1S, A1SA, N1, N15, N1F, N4, N45, N55, N5M, SFL, SFL1, SFY, SFY1, T1AH
	13101-Z1T-010	PISTON(STD.)	1	-----	-----	A1N5, N1F5, N4N5, N6W, SFE, SFE1, SFE4, SFJ, SFN1, SFNR
	13101-ZH8-020	1	-----	-----	A1N5, N1F5, N4N5, N6W, SFE, SFE1, SFE4, SFJ, SFN1, SFNR
	13102-ZH8-020	PISTON(0.25)	(1)	-----	-----	A1N5, N1F5, N4N5, N6W, SFE, SFE1, SFE4, SFJ, SFN1, SFNR
	13103-ZH8-020	PISTON(0.50)	(1)	-----	-----	A1N5, N1F5, N4N5, N6W, SFE, SFE1, SFE4, SFJ, SFN1, SFNR
	13104-ZH8-020	PISTON(0.75)	(1)	-----	-----	A1N5, N1F5, N4N5, N6W, SFE, SFE1, SFE4, SFJ, SFN1, SFNR
	13101-ZDK-013	PISTON(STD.)	1	-----	-----	A1N5/A, A1T5, C14/A, N155, N1B5, N1F5/A, N4N5/A, N6WY, SFE/A, SFE1/A, SFE5, SFL5 SFNR/A, T1A5, TBE5
	13102-ZDK-003	PISTON(0.25)	(1)	-----	-----	A1N5/A, A1T5, C14/A, N155, N1B5, N1F5/A, N4N5/A, N6WY, SFE/A, SFE1/A, SFE5, SFL5 SFNR/A, T1A5, TBE5
	13103-ZDK-003	PISTON(0.50)	(1)	-----	-----	A1N5/A, A1T5, C14/A, N155, N1B5, N1F5/A, N4N5/A, N6WY, SFE/A, SFE1/A, SFE5, SFL5 SFNR/A, T1A5, TBE5
	13104-ZDK-003	PISTON(0.75)	(1)	-----	-----	A1N5/A, A1T5, C14/A, N155, N1B5, N1F5/A, N4N5/A, N6WY, SFE/A, SFE1/A, SFE5, SFL5 SFNR/A, T1A5, TBE5
	13101-Z1T-000	PISTON(STD.)	1	-----	1250645	C12, C14, N4C, N5, N6, N6S, SFC
	13101-ZH8-010	1	-----	1250645	C12, C14, N4C, N5, N6, N6S, SFC
	13102-ZE7-020	PISTON(0.25)	(1)	-----	1250645	C12, C14, N4C, N5, N6, N6S, SFC
	13103-ZE7-020	PISTON(0.50)	(1)	-----	1250645	C12, C14, N4C, N5, N6, N6S, SFC
	13104-ZE7-020	PISTON(0.75)	(1)	-----	1250645	C12, C14, N4C, N5, N6, N6S, SFC
	13101-Z1T-010	PISTON(STD.)	1	1250646	-----	C12, C14, N4C, N5, N6, N6S, SFC
	13101-ZH8-020	1	1250646	-----	C12, C14, N4C, N5, N6, N6S, SFC
	13102-ZH8-020	PISTON(0.25)	(1)	1250646	-----	C12, C14, N4C, N5, N6, N6S, SFC
	13103-ZH8-020	PISTON(0.50)	(1)	1250646	-----	C12, C14, N4C, N5, N6, N6S, SFC

E-7

CRANKSHAFT/PISTON

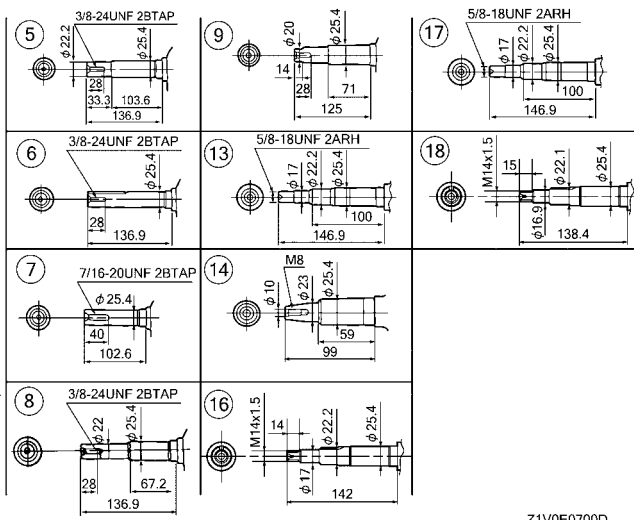
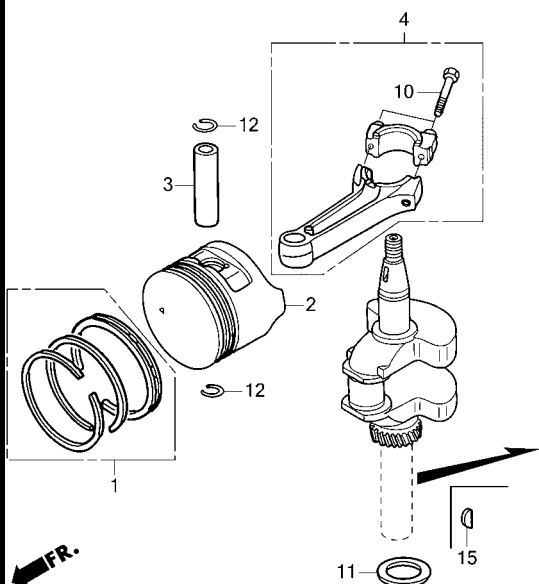

Z1V0E0700D

Ref. No.	Part No.	Description	Reqd. QTY		Serial No.	Parts catalogue code
			GXV 160 H2			
(2)	13104-ZH8-020	PISTON(0.75).....	(1)	1250646	-----	C12,C14,N4C,N5,N6,N6S,SFC
3	13111-Z1T-000	PIN, PISTON.....	1			
4	13200-Z1V-000	ROD ASSY., CONNECTING.....	1			A14,A1S,A1SA,N1,N15,N1F,N4,N45,N55,N5M,N6S,SFL,SFL1,SFY,SFY1,T1AH
	13200-Z1V-600	(IDENT MARK Z)	1			A1N5,A1N5/A,A1T5,C12,C14,C14/A,N155,N1B5,N1F5,N1F5/A,N4C,N4N5,N4N5/A,N5N6,N6W,N6WY,SFC,SFE,SFE/A,SFE1,SFE1/A,SFE4,SFE5,SFJ,SFL5,SFN1,SFNR,SFNR/A,T1A5,TBE5
	13200-Z1V-610		1			A1N5/A,A1T5,C14/A,N155,N1B5,N1F5/A,N4N5/A,N6WY,SFE/A,SFE1/A,SFE5,SFL5,SFNR/A,T1A5,TBE5
5	13310-ZE7-010	CRANKSHAFT COMP.....	1	2571539	-----	A1N5,C12,C14,N1F5,N4C,N4N5,N5,N6,N6W,SFC,SFE,SFE1,SFE4,SFJ,SFN1,SFNR,A14,A1N5,A1N5/A,A1S,A1SA,C14,C14/A,N1,N15,N155,N1B5,N1F,N1F5,N1F5/A
6	13310-ZE7-641	CRANKSHAFT COMP.....	1			N4,N45,N4C,N4N5,N4N5/A
7	13310-ZE7-661	CRANKSHAFT COMP.....	1			N5,N55
8	13310-ZE7-681	CRANKSHAFT COMP.....	1			N6,N6W,N6WY
9	13310-ZE7-771	CRANKSHAFT COMP.....	1			C12,N6S,SFC,SFE,SFE/A,SFE1,SFE1/A,SFE4,SFE5,SFJ,SFL,SFL1,SFL5,SFN1,SFNR,SFNR/A,SFY,SFY1
10	90001-ZE1-000	BOLT, CONNECTING ROD.....	2			A14,A1S,A1SA,N1,N15,N1F,N4,N45,N55,N5M,N6S,SFL,SFL1,SFY,SFY1,T1AH
	90001-Z1T-000	(FOR 13200-Z1V-600)	2			A1N5,A1N5/A,A1T5,C12,C14,C14/A,N155,N1B5,N1F5,N1F5/A,N4C,N4N5,N4N5/A,N5N6,N6W,N6WY,SFC,SFE,SFE/A,SFE1,SFE1/A,SFE4,SFE5,SFJ,SFL5,SFN1,SFNR,SFNR/A,T1A5,TBE5
11	90401-ZE7-W00	WASHER, THRUST, 25.6MM.....	1			
12	90551-ZE1-000	CLIP, PISTON PIN, 18MM.....	2			
13	13310-ZE7-V20	CRANKSHAFT COMP.....	1			T1AH
14	13310-ZE7-U41	CRANKSHAFT COMP.....	1			N5M
15	90741-ZV4-000	KEY, SPECIAL, 16X15.....	1			A1SA

E-7

CRANKSHAFT/PISTON

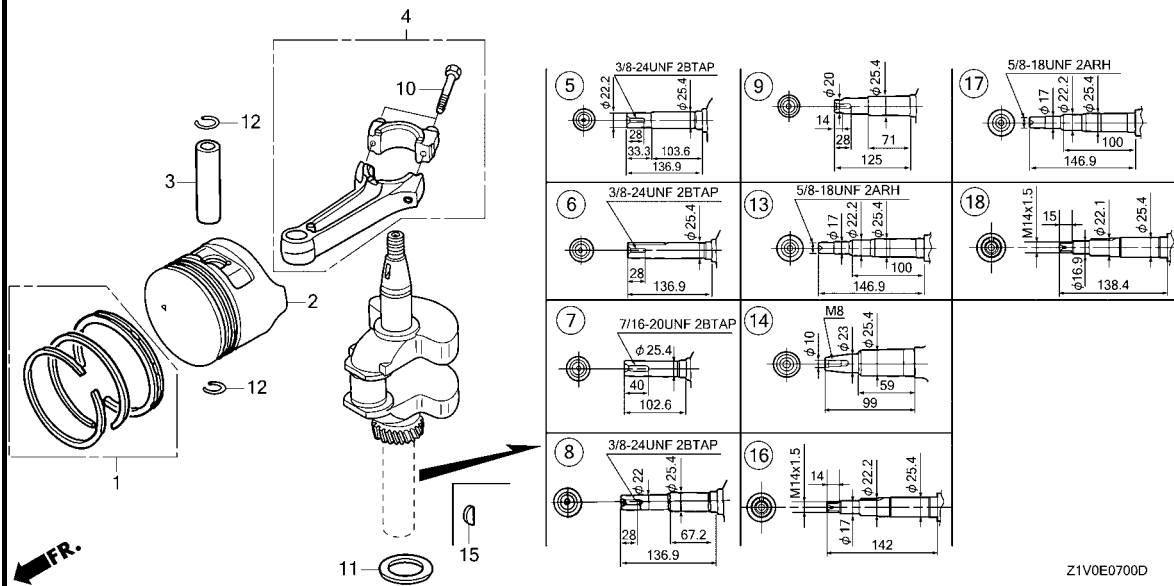

Ref. No.	Part No.	Description	Reqd. QTY		Serial No.	Parts catalogue code
			GXV	H2		
16	13310-Z4P-800	CRANKSHAFT COMP.	1	-----	-----	TBE5
17	13310-ZE7-V10	CRANKSHAFT COMP.	1	-----	-----	A1T5
18	13310-ZE7-V21	CRANKSHAFT COMP.	1	-----	-----	T1A5



E-9

CAMSHAFT

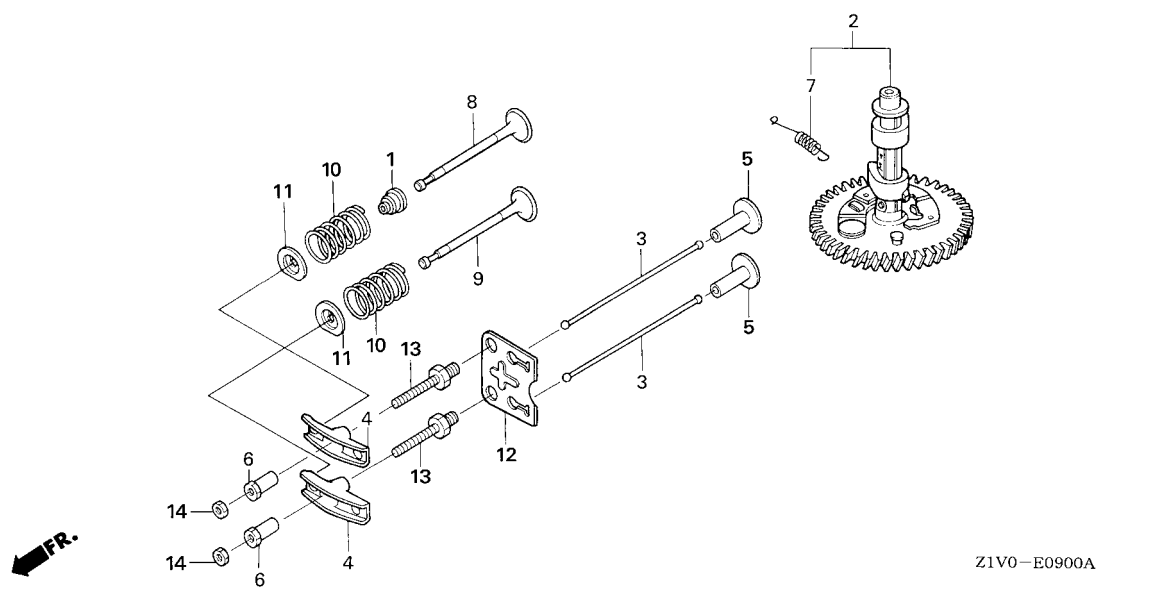

Ref. No.	L.O.N.	(Relative ref. Number) Description	F.R.T.
1	1111K2	SEAL, INTAKE VALVE STEMINCLUDES: Valve clearance adjustment	0.7
2	1111C2	CAMSHAFTINCLUDES: Valve clearance adjustment	0.6
3	1111L6	ROD, PUSH :INTAKEINCLUDES: Valve clearance adjustment	0.2
	1111L6A	.Replace exhaust push rod add	0.1
	1111L7	ROD, PUSH :EXHAUSTINCLUDES: Valve clearance adjustment	0.2
	1111L7A	.Replace intake push rod add	0.1
4	1111A2	ARM, ROCKER :INTAKEINCLUDES: Valve clearance adjustment	0.2
	1111A2A	.Replace exhaust rocker arm add	0.1
	1111A1	ARM, ROCKER :EXHAUSTINCLUDES: Valve clearance adjustment	0.2
	1111A1A	.Replace intake rocker arm add	0.1
5	1111L9	LIFTER, VALVE :INTAKENOTE: Same time for two units	0.6

Z1V0-E0900A

Ref. No.	Part No.	Description	Reqd. QTY	Serial No.	Parts catalogue code	
			GXV 160 H2			
1	12209-ZE6-003	SEAL, VALVE STEM.....	1			
2	14100-ZE7-000	CAMSHAFT ASSY.	1	-----	A14, A1N5, A1N5/A, A1S, A1SA, A1T5, C12, C14, C14/A, N1, N15, N155, N1B5, N1F, N1F5, N1F5/A, N4, N45, N4C, N4N5, N4N5/A, N5, N55, N5M, N6, N6W, N6WY, T1A5, T1AH, TBE5	
	14100-ZE7-770	1	-----	N6S, SFC, SFE, SFE/A, SFE1, SFE1/A, SFE5, SFJ, SFL, SFL1, SFL5, SFN1, SFNR, SFNR/A, SFY, SFY1	
	14100-ZE7-N40	1	-----	N6S, SFE4	
3	14410-ZE1-010	ROD, PUSH	2			
4	14431-ZE1-000	ARM, VALVE ROCKER	2			
	14431-Z1T-000	2	-----	A1N5/A, A1T5, C14/A, N155, N1B5, N1F5/A, N4N5/A, N6WY, SFE/A, SFE1/A, SFE5, SFL5, SFNR/A, T1A5, TBE5	
5	14441-ZE1-010	LIFTER, VALVE	2	2591188	-----	A1N5, C12, C14, N1F5, N4C, N4N5, N5, N6, N6W, SFC, SFE, SFE1, SFE4, SFJ, SFN1, SFNR
6	14451-ZE1-013	PIVOT, ROCKER ARM	2	-----	A14, A1S, A1SA, N1, N15, N1F, N4, N45, N55, N5M, SFL, SFL1, SFY, SFY1, T1AH	
	14451-Z7E-000	2	-----	A1N5, A1N5/A, A1T5, C12, C14, C14/A, N155, N1B5, N1F5, N1F5/A, N4C, N4N5, N4N5/A, N5, N6, N6W, N6WY, SFC, SFE, SFE/A, SFE1, SFE1/A, SFE4, SFE5, SFJ, SFL5, SFN1, SFNR, SFNR/A, T1A5, TBE5	
7	14568-ZE1-000	SPRING, WEIGHT RETURN	1			
8	14711-ZF1-000	VALVE, IN.	1			
9	14721-ZE7-000	VALVE, EX.	1			
10	14751-ZE1-000	SPRING, VALVE	2			
11	14771-ZE1-000	RETAINER, IN. VALVE SPRING	2	-----	A14, A1S, A1SA, N1, N15, N1F, N4, N45, N55, N5M, N6S, SFL, SFL1, SFY, SFY1, T1AH	
	14771-Z1T-000	RETAINER, VALVE SPRING	2	-----	A1N5, A1N5/A, A1T5, C12, C14, C14/A, N155, N1B5, N1F5, N1F5/A, N4C, N4N5, N4N5/A, N5, N6, N6W, N6WY, SFC, SFE, SFE/A, SFE1, SFE1/A, SFE4, SFE5, SFJ, SFL5, SFN1, SFNR, SFNR/A, T1A5, TBE5	
12	14791-ZE1-010	PLATE, PUSH ROD GUIDE	1			
13	90012-ZE0-010	BOLT, PIVOT, 8MM	2			
14	90206-ZE1-000	NUT, PIVOT ADJUSTING	2			

E-9

CAMSHAFT

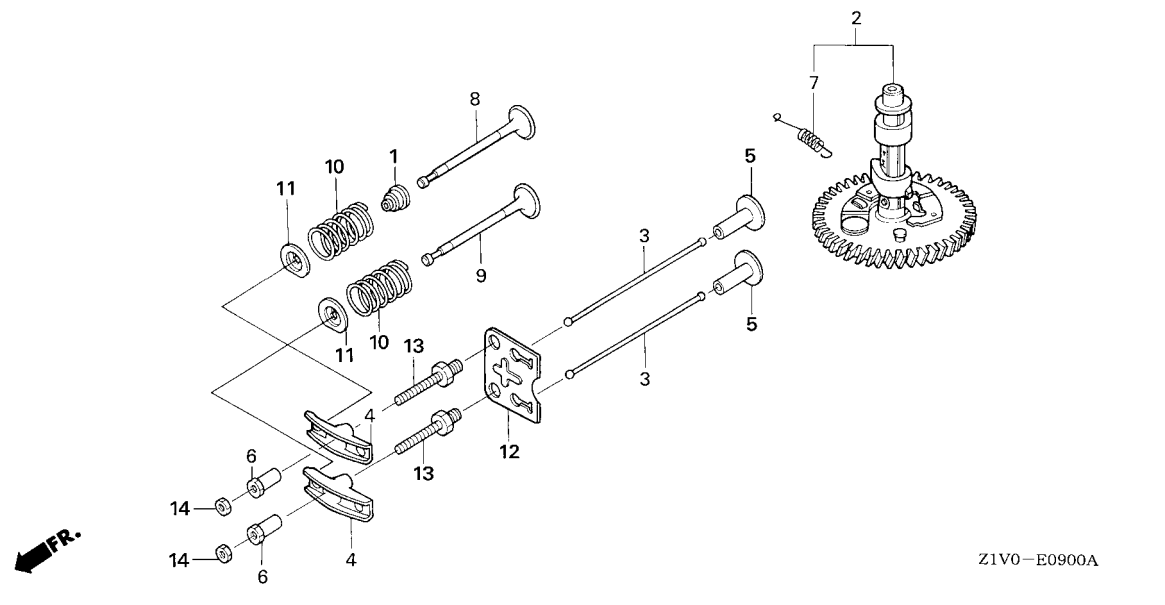

Z1V0-E0900A

Ref. No.	L.O.N.	(Relative ref. Number) Description	F.R.T.
+ 5	1111M0	LIFTER, VALVE :EXHAUSTNOTE: Same time for two units	0.6
8	1111L1	VALVE, INTAKEINCLUDES: Valve clearance adjustment and reface	0.7
	1111L1E	.Replace intake and exhaust all add	0.1
9	1111L0	VALVE, EXHAUSTINCLUDES: Valve clearance adjustment and reface	0.7
	1111L0E	.Replace intake and exhaust all add	0.1
10	1111P3	SPRING, VALVE :INTAKEINCLUDES: Valve clearance adjustment	0.6
	1111P3A	.Replace intake and exhaust all add	0.1
	1111P4	SPRING, VALVE :EXHAUSTINCLUDES: Valve clearance adjustment	0.6
	1111P4A	.Replace intake and exhaust all add	0.1



E-11

RECOIL STARTER(1)

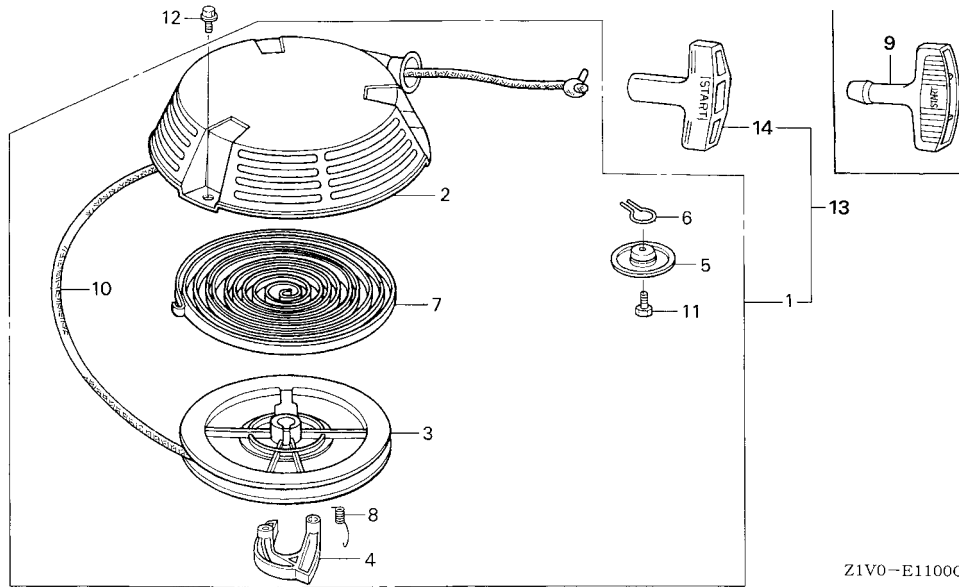

Ref. No.	L.O.N.	(Relative ref. Number) Description	F.R.T.
1	(13)		
1	1121B9	STARTER, RECOIL	0.1
3	1121B1	REEL, RECOIL STARTER	0.3
4	(8)		
1	1121B0	STARTER RATCHET AND/OR SPRING	0.2
7	1121B7	SPRING, RECOIL STARTER RETURN	0.3
10	1121B3	ROPE, RECOIL STARTER	0.3

Ref. No.	Part No.	Description	Reqd. QTY GXV 160 H2	Serial No.	Parts catalogue code
1	28400-Z1V-J51ZA	STARTER ASSY., RECOIL (LONG ROPE)	1	1098141 A1S,A1SA,N5M	
		R280.....POWER RED	1	1098141 A1S,A1SA,N5M	
		NH1.....BLACK	1	1098141 A1S,A1SA,N5M	
2	28410-ZE7-003ZB	CASE COMP., RECOIL STARTER	1	1098141 A14,A1S,A1SA,N15,N1F,N45,N55,N5M	
		NH1.....BLACK	1	1098141 A14,A1S,A1SA,N15,N1F,N45,N55,N5M	
		R280.....POWER RED	1	1113862 C12,C14,N1,N4,N5,N6,N6S,SFC,SFL,SFL1,SFY,SFY1	
			1	1113862 SFL1,T1AH	
			1	1098141 A14,A1S,A1SA,N15,N1F,N45,N55,N5M	
			1	1113862 C12,C14,N1,N4,N5,N6,N6S,SFC,SFL,SFL1,SFY,SFY1,T1AH	
3	28420-ZE7-003	PULLEY, RECOIL STARTER.....	1	1098141 A14,A1S,A1SA,N15,N1F,N45,N55,N5M	
			1	1113862 C12,C14,N1,N4,N5,N6,N6S,SFC,SFL,SFL1,SFY,SFY1,T1AH	
4	28422-896-010	RATCHET, STARTER.....	1	1098141 A14,A1S,A1SA,N15,N1F,N45,N55,N5M	
			1	1113862 C12,C14,N1,N4,N5,N6,N6S,SFC,SFL,SFL1,SFY,SFY1,T1AH	
5	28431-896-000	PLATE, FRICTION.....	1	1098141 A14,A1S,A1SA,N15,N1F,N45,N55,N5M	
			1	1113862 C12,C14,N1,N4,N5,N6,N6S,SFC,SFL,SFL1,SFY,SFY1,T1AH	
6	28441-896-000	SPRING, FRICTION.....	1	1098141 A14,A1S,A1SA,N15,N1F,N45,N55,N5M	
			1	1113862 C12,C14,N1,N4,N5,N6,N6S,SFC,SFL,SFL1,SFY,SFY1,T1AH	
7	28442-896-700	SPRING, RECOIL STARTER.....	1	1098141 A14,A1S,A1SA,N15,N1F,N45,N55,N5M	
			1	1113862 C12,C14,N1,N4,N5,N6,N6S,SFC,SFL,SFL1,SFY,SFY1,T1AH	
8	28443-896-000	SPRING, RETURN.....	1	1098141 A14,A1S,A1SA,N15,N1F,N45,N55,N5M	
			1	1113862 C12,C14,N1,N4,N5,N6,N6S,SFC,SFL,SFL1,SFY,SFY1,T1AH	
9	28461-ZE7-T00	GRIP, STARTER.....	1	1098141 A1S,A1SA,N5M	
10	28462-ZA7-003	ROPE, RECOIL STARTER.....	1	1098141 A14	
			1	1098141 A1S,A1SA,N15,N1F,N45,N55,N5M	
			1	1113862 C12,C14,N1,N4,N5,N6,N6S,SFC,SFL,SFL1,SFY,SFY1,T1AH	
11	92101-06012-0H	BOLT, HEX., 6X12.....	1	1098141 A14,A1S,A1SA,N15,N1F,N45,N55,N5M	
			1	1113862 C12,C14,N1,N4,N5,N6,N6S,SFC,SFL,SFL1,SFY,SFY1,T1AH	

E-11

RECOIL STARTER(1)

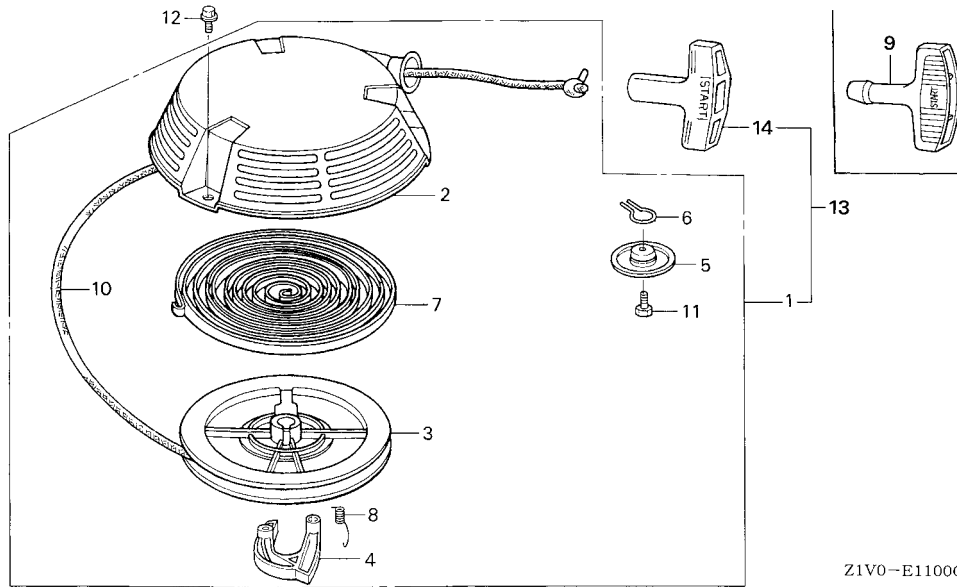

Ref. No.	Part No.	Description	Reqd. QTY		Serial No.	Parts catalogue code
			GXV	H2		
12	95701-06008-00	BOLT, FLANGE, 6X8	3	-----	1098141 A14, A15, A1SA, N15, N1F, N45, N55, N5M	
13	28400-ZE7-003ZB	STARTER ASSY., RECOIL	3	-----	1113862 C12, C14, N1, N4, N5, N6, N6S, SFC, SFL, SFL1, SFY, SFY1, T1AH	
		NH1.....BLACK	1	-----	1098141 A14	
	28400-ZE7-003ZC	*R280*.....POWER RED	1	-----	1098141 A14	
	28400-ZE7-V11ZB	STARTER ASSY., RECOIL (LONG ROPE)				
		NH1.....BLACK	1	-----	1098141 N15, N1F, N45, N55	
	28400-ZE7-V11ZC	*R280*.....POWER RED	1	-----	1098141 N15, N1F, N45, N55	
	28400-ZE7-003ZC	STARTER ASSY., RECOIL				
		R280.....POWER RED	1	-----	1113862 C12, C14, N1, N4, N5, N6, N6S, SFC, SFL, SFL1, SFY, SFY1	
	28400-ZE7-003ZB	*NH1*.....BLACK	1	-----	1113862 SFL1, T1AH	
14	28461-ZE1-003	KNOB, RECOIL STARTER.....	1	-----	1098141 A14, N15, N1F, N45, N55	
			1	-----	1113862 C12, C14, N1, N4, N5, N6, N6S, SFC, SFL, SFL1, SFY, SFY1, T1AH	



E-11-1

RECOIL STARTER(2)

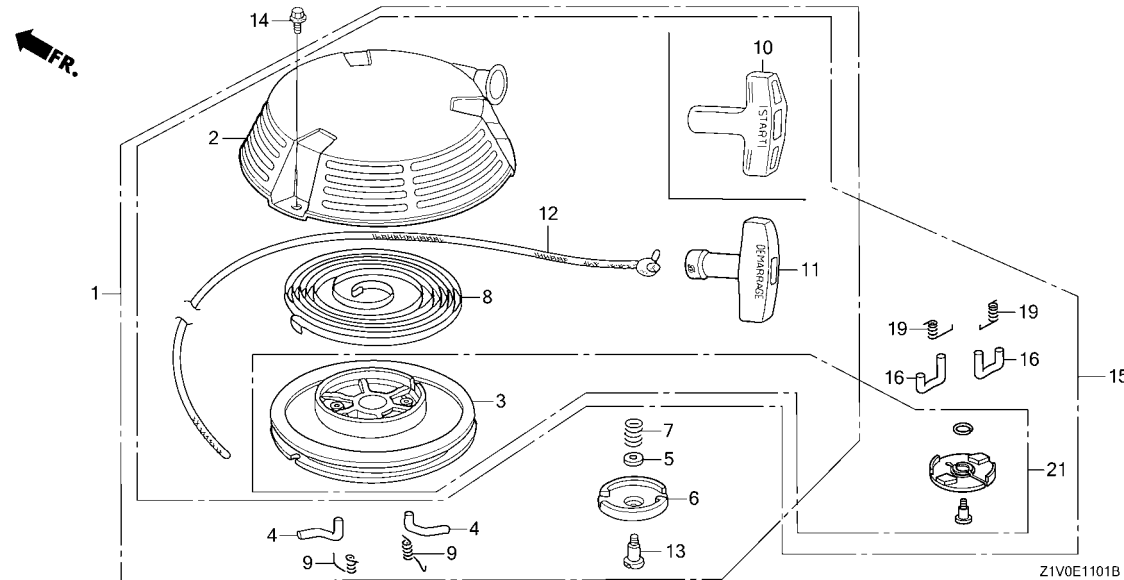

Ref. No.	L.O.N.	(Relative ref. Number) Description	F.R.T.
1		(15)	
1121B9		STARTER, RECOIL	0.1
3		(21)	
1121B1		REEL, RECOIL STARTER	0.3
4		(9,16,19)	
1121B0		STARTER RATCHET AND/OR SPRING .NOTE: Same time for two units	0.2
6		(7)	
1121A4		GUIDE, RATCHET	0.2
8		1121B7 SPRING, RECOIL STARTER RETURN	0.3
12		1121B3 ROPE, RECOIL STARTER	0.3

Ref. No.	Part No.	Description	Reqd. QTY	Serial No.	Parts catalogue code
			GXV 160 H2		
1	28400-Z1V-003ZB	STARTER ASSY., RECOIL	1		
		R280.....POWER RED	1	1510263	N4C,N6W
	28400-Z1V-013ZB	*R280*.....POWER RED	1	1915342	SFE,SFE1,SFE4
	28400-Z1V-013ZA	*NH1*.....BLACK	1	1915342	SFE1,SFE4,SFN1
	28400-Z1V-802ZA	STARTER ASSY., RECOIL (LONG ROPE)	1		
		NH1.....BLACK	1	1916287	A1N5,N1F5,N4N5,SFJ
	28400-Z1V-801ZA	*NH1*.....BLACK	1	1098142	A14,A1S,A1SA,N15,N1F,N45,N55,N5M
	28400-Z1V-801ZB	*R280*.....POWER RED	1	1098142	A14,A1S,A1SA,N15,N1F,N45,N55,N5M
	28400-Z1V-003ZB	STARTER ASSY., RECOIL	1		
		R280.....POWER RED	1	1113863	N1,N4,SFL,SFL1,SFY,SFY1
	28400-Z1V-003ZA	*NH1*.....BLACK	1	1113863	SFL1,T1AH
	28400-Z1V-003ZB	*R280*.....POWER RED	1	1113863	1510263 C12,C14,N5,N6,N6S,SFC
	28400-Z1V-013ZB	*R280*.....POWER RED	1	1510264	N6S
			1	1510264	1915342 C12,C14,N4C,N5,N6,N6W,SFC
2	28410-Z1V-003ZA	CASE COMP., RECOIL STARTER	1		
		R280.....POWER RED	1	1915342	N4C,N6W,SFE,SFE1,SFE4
	28410-Z1V-003ZB	*NH1*.....BLACK	1	1915342	SFE1,SFE4,SFN1
			1	1916287	A1N5,N1F5,N4N5,SFJ
	28410-Z1V-003ZA	*R280*.....POWER RED	1	1098142	A14,A1S,A1SA,N15,N1F,N45,N55,N5M
	28410-Z1V-003ZB	*NH1*.....BLACK	1	1098142	A14,A1S,A1SA,N15,N1F,N45,N55,N5M
	28410-Z1V-003ZA	*R280*.....POWER RED	1	1113863	N1,N4,N6S,SFL,SFL1,SFY,SFY1
	28410-Z1V-003ZB	*NH1*.....BLACK	1	1113863	SFL1,T1AH
	28410-Z1V-003ZA	*R280*.....POWER RED	1	1113863	1915342 C12,C14,N5,N6,SFC
	28410-Z1V-701ZB	*R280*.....POWER RED	1	1915343	2019698 C12,C14,N4C,N5,N6,N6W,SFC,SFE,SFE1,SFE4
	28410-Z1V-701ZA	*NH1*.....BLACK	1	1915343	2019698 SFE1,SFE4,SFN1
			1	1916288	2021761 A1N5,N1F5,N4N5,SFJ

E-11-1

RECOIL STARTER(2)

Ref. No.	Part No.	Description	Reqd. QTY	Serial No.	Parts catalogue code
			GxV 160 H2		
3	28420-Z1V-003	REEL, RECOIL STARTER(BLACK) ..	1	----- 1915342	N4C,N6W,SFE,SFE1,SFE4,SFN1
			1	----- 1916287	A1N5,N1F5,N4N5,SFJ
			1	1098142	----- A14,A1S,A1SA,N15,N1F,N45,N55,N5M
			1	1113863	----- N1,N4,N6S,SFL,SFL1,SFY,SFY1,T1AH
			1	1113863	1915342 C12,C14,N5,N6,SFC
4	28422-ZH8-801	RATCHET, STARTER	2	----- 1915342	N4C,N6W,SFE,SFE1,SFE4,SFN1
			2	----- 1916287	A1N5,N1F5,N4N5,SFJ
			2	1098142	----- A14,A1S,A1SA,N15,N1F,N45,N55,N5M
			2	1113863	----- N1,N4,N6S,SFL,SFL1,SFY,SFY1,T1AH
			2	1113863	1915342 C12,C14,N5,N6,SFC
5	28431-ZH8-801	PLATE, FRICTION	1	----- 1915342	N4C,N6W,SFE,SFE1,SFE4,SFN1
			1	----- 1916287	A1N5,N1F5,N4N5,SFJ
			1	1098142	----- A14,A1S,A1SA,N15,N1F,N45,N55,N5M
			1	1113863	----- N1,N4,N6S,SFL,SFL1,SFY,SFY1,T1AH
			1	1113863	1915342 C12,C14,N5,N6,SFC
6	28433-ZH8-801	GUIDE, RATCHET	1	----- 1915342	N4C,N6W,SFE,SFE1,SFE4,SFN1
			1	----- 1916287	A1N5,N1F5,N4N5,SFJ
			1	1098142	----- A14,A1S,A1SA,N15,N1F,N45,N55,N5M
			1	1113863	----- N1,N4,N6S,SFL,SFL1,SFY,SFY1,T1AH
			1	1113863	1915342 C12,C14,N5,N6,SFC
7	28441-ZH8-801	SPRING, FRICTION	1	----- 1915342	N4C,N6W,SFE,SFE1,SFE4,SFN1
			1	----- 1916287	A1N5,N1F5,N4N5,SFJ
			1	1098142	----- A14,A1S,A1SA,N15,N1F,N45,N55,N5M
			1	1113863	----- N1,N4,N6S,SFL,SFL1,SFY,SFY1,T1AH
			1	1113863	1915342 C12,C14,N5,N6,SFC
8	28442-ZH8-003	SPRING, RECOIL STARTER	1	----- 2019698	N4C,N6W,SFE,SFE1,SFE4,SFN1
			1	----- 2021761	A1N5,N1F5,N4N5,SFJ
			1	1098142	----- A14,A1S,A1SA,N15,N1F,N45,N55,N5M
			1	1113863	----- N1,N4,N6S,SFL,SFL1,SFY,SFY1,T1AH
			1	1113863	2019698 C12,C14,N5,N6,SFC
9	28443-ZH8-801	SPRING, RETURN	2	----- 1915342	N4C,N6W,SFE,SFE1,SFE4,SFN1
			2	----- 1916287	A1N5,N1F5,N4N5,SFJ
			2	1098142	----- A14,A1S,A1SA,N15,N1F,N45,N55,N5M
			2	1113863	----- N1,N4,N6S,SFL,SFL1,SFY,SFY1,T1AH
			2	1113863	1915342 C12,C14,N5,N6,SFC
10	28461-ZE1-013	KNOB, RECOIL STARTER	1	----- 2021761	A1N5,N1F5,N4N5,SFJ
	28461-ZE1-003 (FOR LONG ROPE)	1	1098142	----- A14,A1S,A1SA,N15,N1F,N45,N55,N5M
11	28461-ZH8-003	KNOB, RECOIL STARTER	1	----- 1510263	N4C,N6W
	28461-ZH8-013	1	----- 2019698	SFE,SFE1,SFE4,SFN1
	28461-ZH8-003	1	1113863	----- N1,N4,SFL,SFL1,SFY,SFY1,T1AH
			1	1113863	1510263 C12,C14,N5,N6,N6S,SFC
	28461-ZH8-013	1	----- 1510264	N6S
			1	1510264	2019698 C12,C14,N4C,N5,N6,N6W,SFC
12	28462-ZH8-003	ROPE, RECOIL STARTER	1	----- 1915342	N4C,N6W,SFE,SFE1,SFE4,SFN1
	28462-Z1V-801	ROPE, RECOIL STARTER(LONG) (2360MM)	1	----- 1916287	A1N5,N1F5,N4N5,SFJ
			1	1098142	----- A14,A1S,A1SA,N15,N1F,N45,N55,N5M
	28462-ZH8-003	ROPE, RECOIL STARTER	1	1113863	----- N1,N4,N6S,SFL,SFL1,SFY,SFY1,T1AH
			1	1113863	1915342 C12,C14,N5,N6,SFC
	28462-Z1T-701	1	1915343	2019698 C12,C14,N4C,N5,N6,N6W,SFC,SFE,SFE1,SFE4,SFN1
	28462-Z1V-811	ROPE, RECOIL STARTER (LONG TYPE)	1	1916288	2021761 A1N5,N1F5,N4N5,SFJ



E-11-1

RECOIL STARTER(2)

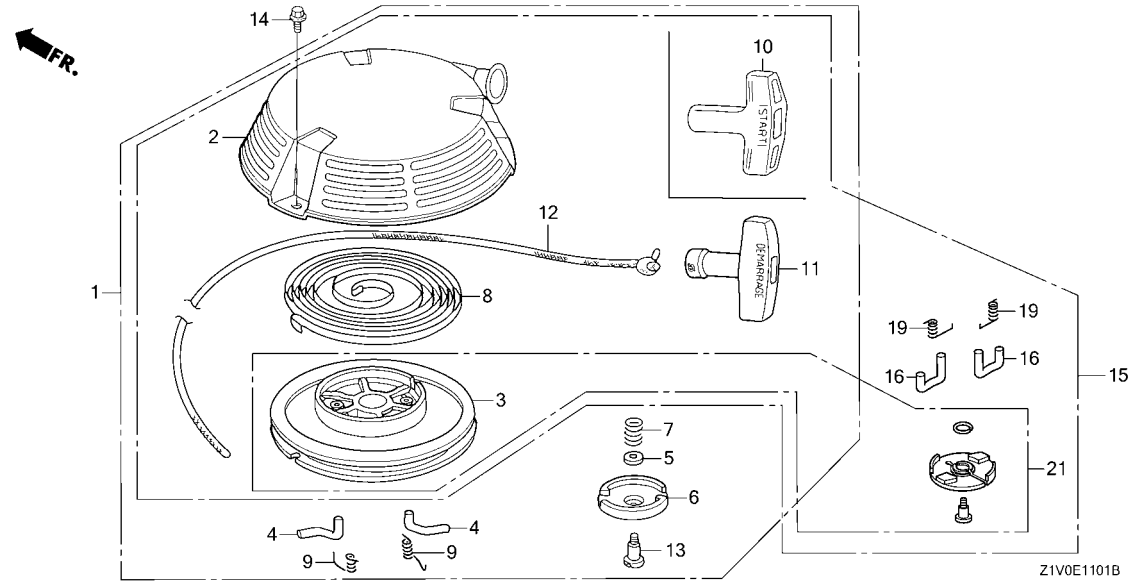

Ref. No.	Part No.	Description	Reqd. QTY		Serial No.	Parts catalogue code
			GXV 160 H2			
13	90003-ZH8-801	SCREW, SETTING	1	-----	1915342	N4C, N6W, SFE, SFE1, SFE4, SFN1
			1	-----	1916287	A1N5, N1F5, N4N5, SFJ
			1	1098142	-----	A14, A1S, A1SA, N15, N1F, N45, N55, N5M
			1	1113863	-----	N1, N4, N6S, SFL, SFL1, SFY, SFY1, T1AH
14	95701-06008-00	BOLT, FLANGE, 6X8	1	1113863	1915342	C12, C14, N5, N6, SFC
			3	-----	2019698	N4C, N6W, SFE, SFE1, SFE4, SFN1
			3	-----	2021761	A1N5, N1F5, N4N5, SFJ
			3	1098142	-----	A14, A1S, A1SA, N15, N1F, N45, N55, N5M
15	28400-Z1V-701ZB	STARTER ASSY., RECOIL	3	1113863	-----	N1, N4, N6S, SFL, SFL1, SFY, SFY1, T1AH
			3	1113863	2019698	C12, C14, N5, N6, SFC
			1	1915343	2019698	C12, C14, N4C, N5, N6, N6W, SFC, SFE, SFE1, SFE4
			1	1915343	2019698	SFE1, SFE4, SFN1
	28400-Z1V-702ZA	*NH1*.....BLACK	1	1915343	2019698	SFE1, SFE4, SFN1
	28400-Z1V-811ZA	STARTER ASSY., RECOIL (LONG ROPE)	1	1916288	2021761	A1N5, N1F5, N4N5, SFJ
		NH1.....BLACK	1	1916288	2021761	A1N5, N1F5, N4N5, SFJ
16	28422-Z1T-701	RATCHET, STARTER	2	1915343	2019698	C12, C14, N4C, N5, N6, N6W, SFC, SFE, SFE1, SFE4, SFN1
			2	1916288	2021761	A1N5, N1F5, N4N5, SFJ
19	28443-Z1T-701	SPRING, RETURN	2	1915343	2019698	C12, C14, N4C, N5, N6, N6W, SFC, SFE, SFE1, SFE4, SFN1
			2	1916288	2021761	A1N5, N1F5, N4N5, SFJ
21	06280-Z1V-305	STARTER SET, RECOIL	1	1915343	2019698	C12, C14, N4C, N5, N6, N6W, SFC, SFE, SFE1, SFE4, SFN1
			1	1916288	2021761	A1N5, N1F5, N4N5, SFJ



E-11-2

RECOIL STARTER(3)

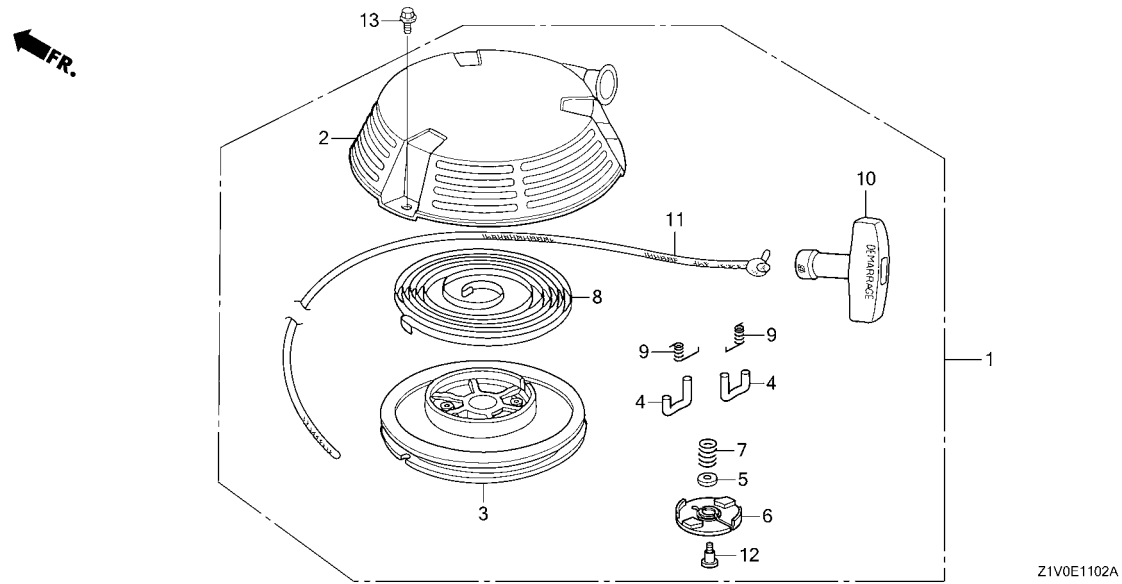

Ref. No.	L.O.N.	(Relative ref. Number) Description	F.R.T.
1	1121B9	STARTER, RECOIL	0.1
3	1121B1	REEL, RECOIL STARTER	0.3
4	1121B0	STARTER RATCHET AND/OR SPRING .NOTE: Same time for two units (7)	0.2
6	1121A4	GUIDE, RATCHET	0.2
8	1121B7	SPRING, RECOIL STARTER RETURN	0.3
11	1121B3	ROPE, RECOIL STARTER	0.3

Ref. No.	Part No.	Description	Reqd. QTY	Serial No.	Parts catalogue code
			GXV 160 H2		
1	28400-Z1V-812ZA	STARTER ASSY., RECOIL (LONG ROPE)	1		
	NH1BLACK	1	-----	A1N5/A, N155, N1B5, N1F5/A, N4N5/A
	28400-Z1V-831ZA	*R280*.....POWER RED	1	-----	A1T5
	28400-Z1V-831ZB	*NH1*.....BLACK	1	-----	A1T5
	28400-Z1V-702ZB	STARTER ASSY., RECOIL *R280*.....POWER RED	1	-----	C14/A, SFE/A, SFE1/A, SFE5, SFL5, SFNR, SFNR/A, T1A5, TBE5
	28400-Z1V-812ZB	STARTER ASSY., RECOIL (LONG ROPE)	1	-----	N155
	28400-Z1V-702ZA	STARTER ASSY., RECOIL *NH1*.....BLACK	1	-----	N6WY, SFE/A, SFE1/A, SFE5, SFL5, T1A5, TBE5
	28400-Z1V-702ZB	*R280*.....POWER RED	1	2019699	-----
	28400-Z1V-702ZA	*NH1*.....BLACK	1	2019699	-----
	28400-Z1V-812ZA	STARTER ASSY., RECOIL (LONG ROPE)	1	2021762	-----
	NH1BLACK	1	-----	A1N5, N1F5, N4N5, SFJ
2	28410-Z1V-701ZA	CASE COMP., RECOIL STARTER *NH1*.....BLACK	1	-----	A1N5/A, A1T5, N155, N1B5, N1F5/A, N4N5/A, N6WY, SFE/A, SFE1/A, SFE5, SFL5, T1A5, TBE5
	28410-Z1V-701ZB	*R280*.....POWER RED	1	-----	A1T5, C14/A, N155, SFE/A, SFE1/A, SFE5, SFL5, SFNR, SFNR/A, T1A5, TBE5
			1	2019699	-----
	28410-Z1V-701ZA	*NH1*.....BLACK	1	2019699	-----
			1	2021762	-----
			1	-----	A1N5, N1F5, N4N5, SFJ
3	28420-Z1V-702	REEL, RECOIL STARTER(BLACK) ..	1	-----	A1N5/A, A1T5, C14/A, N155, N1B5, N1F5/A, N4N5/A, N6WY, SFE/A, SFE1/A, SFE5, SFL5, SFNR, SFNR/A, T1A5, TBE5
			1	2019699	-----
			1	2021762	-----
			1	-----	A1N5, N1F5, N4N5, SFJ



E-11-2

RECOIL STARTER(3)

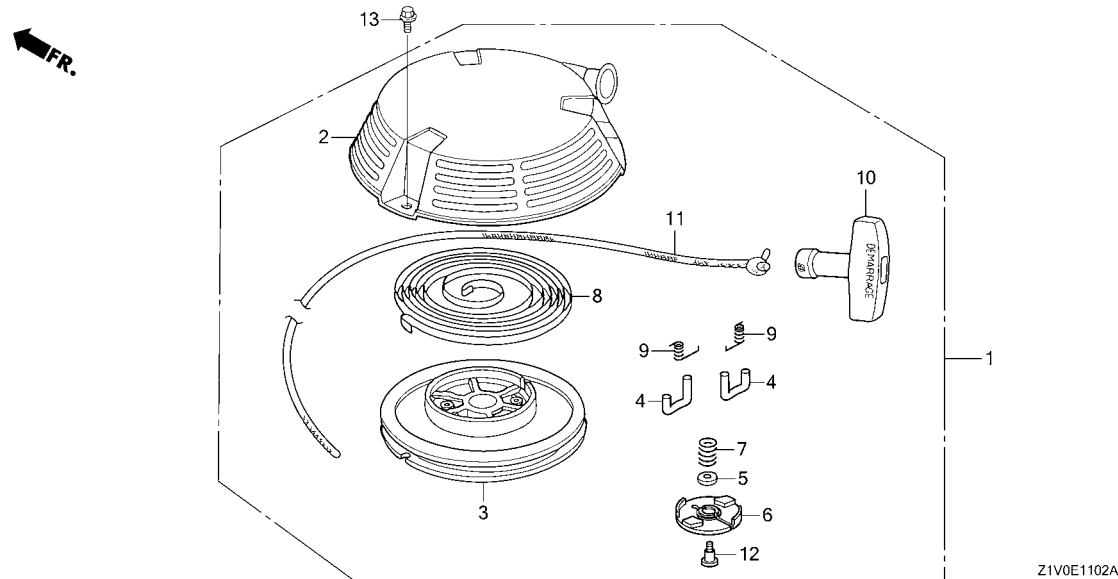

Ref. No.	Part No.	Description	Reqd. QTY		Serial No.	Parts catalogue code
			GXV	H2		
4	28422-Z1T-701	RATCHET, STARTER.....	2	-----	-----	A1N5/A, A1T5, C14/A, N155, N1B5, N1F5/A, N4N5/A, N6WY, SFE/A, SFE1/A, SFE5, SFL5 SFNR, SFNR/A, T1A5, TBE5
			2	2019699	-----	C12, C14, N4C, N5, N6, N6W, SFC, SFE, SFE1, SFE4, SFN1
			2	2021762	-----	A1N5, N1F5, N4N5, SFJ
5	28431-ZH8-801	PLATE, FRICTION.....	1	-----	-----	A1N5/A, A1T5, C14/A, N155, N1B5, N1F5/A, N4N5/A, N6WY, SFE/A, SFE1/A, SFE5, SFL5 SFNR, SFNR/A, T1A5, TBE5
			1	2019699	-----	C12, C14, N4C, N5, N6, N6W, SFC, SFE, SFE1, SFE4, SFN1
			1	2021762	-----	A1N5, N1F5, N4N5, SFJ
6	28433-Z1T-702	GUIDE, RATCHET.....	1	-----	-----	A1N5/A, A1T5, C14/A, N155, N1B5, N1F5/A, N4N5/A, N6WY, SFE/A, SFE1/A, SFE5, SFL5 SFNR, SFNR/A, T1A5, TBE5
			1	2019699	-----	C12, C14, N4C, N5, N6, N6W, SFC, SFE, SFE1, SFE4, SFN1
			1	2021762	-----	A1N5, N1F5, N4N5, SFJ
7	28441-ZH8-801	SPRING, FRICTION.....	1	-----	-----	A1N5/A, A1T5, C14/A, N155, N1B5, N1F5/A, N4N5/A, N6WY, SFE/A, SFE1/A, SFE5, SFL5 SFNR, SFNR/A, T1A5, TBE5
			1	2019699	-----	C12, C14, N4C, N5, N6, N6W, SFC, SFE, SFE1, SFE4, SFN1
			1	2021762	-----	A1N5, N1F5, N4N5, SFJ
8	28442-ZH8-003	SPRING, RECOIL STARTER.....	1	-----	-----	A1N5/A, A1T5, C14/A, N155, N1B5, N1F5/A, N4N5/A, N6WY, SFE/A, SFE1/A, SFE5, SFL5 SFNR, SFNR/A, T1A5, TBE5
			1	2019699	-----	C12, C14, N4C, N5, N6, N6W, SFC, SFE, SFE1, SFE4, SFN1
			1	2021762	-----	A1N5, N1F5, N4N5, SFJ
9	28443-Z1T-701	SPRING, RETURN.....	2	-----	-----	A1N5/A, A1T5, C14/A, N155, N1B5, N1F5/A, N4N5/A, N6WY, SFE/A, SFE1/A, SFE5, SFL5 SFNR, SFNR/A, T1A5, TBE5
			2	2019699	-----	C12, C14, N4C, N5, N6, N6W, SFC, SFE, SFE1, SFE4, SFN1
			2	2021762	-----	A1N5, N1F5, N4N5, SFJ
10	28461-ZE1-013	KNOB, RECOIL STARTER.....	1	-----	-----	A1N5/A, A1T5, N155, N1B5, N1F5/A, N4N5/A
	28461-ZH8-013	1	-----	-----	C14/A, N6WY, SFE/A, SFE1/A, SFE5, SFL5, SFNR, SFNR/A, T1A5, TBE5
			1	2019699	-----	C12, C14, N4C, N5, N6, N6W, SFC, SFE, SFE1, SFE4, SFN1
	28461-ZE1-013	1	2021762	-----	A1N5, N1F5, N4N5, SFJ

E-11-2

RECOIL STARTER(3)

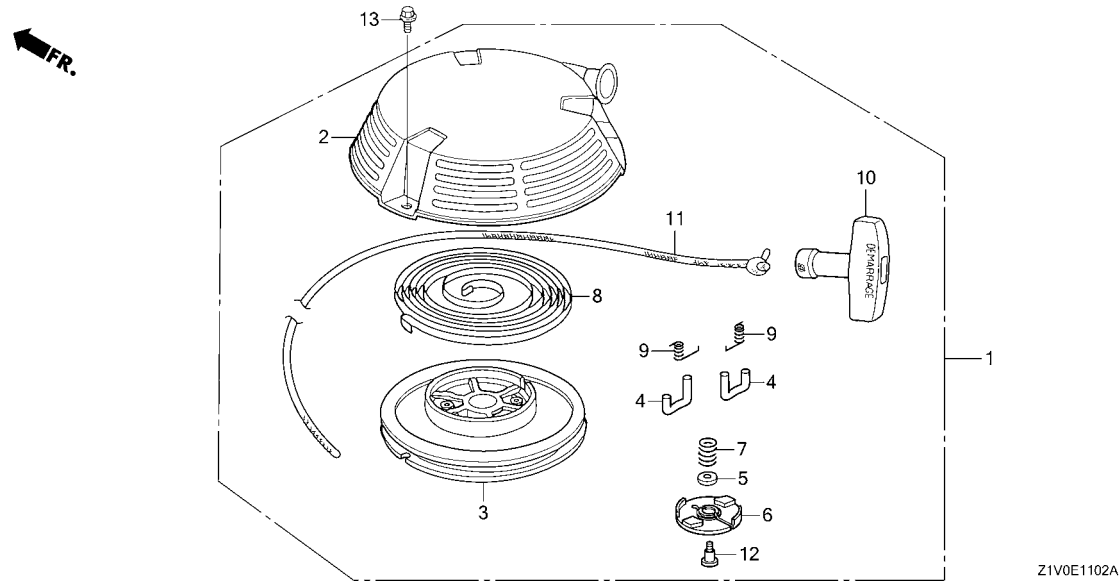

Ref. No.	Part No.	Description	Reqd. QTY		Serial No.	Parts catalogue code
			GXV	H2		
11	28462-Z1V-811	ROPE, RECOIL STARTER (LONG TYPE)	1	-----	-----	A1N5/A, N155, N1B5, N1F5/A, N4N5/A
	28462-Z1V-831	ROPE, RECOIL STARTER.....	1	-----	-----	A1T5
	28462-Z1T-701	1	-----	-----	C14/A, N6WY, SFE/A, SFE1/A, SFE5, SFL5, SFNR, SFNR/A, T1A5, TBE5
	28462-Z1V-811	ROPE, RECOIL STARTER (LONG TYPE)	1	2019699	-----	C12, C14, N4C, N5, N6, N6W, SFC, SFE, SFE1, SFE4, SFN1
12	90003-ZH8-801	SCREW, SETTING.....	1	-----	-----	A1N5, N1F5, N4N5, SFJ
			1	2019699	-----	A1N5/A, A1T5, C14/A, N155, N1B5, N1F5/A, N4N5/A, N6WY, SFE/A, SFE1/A, SFE5, SFL5, SFNR, SFNR/A, T1A5, TBE5
			1	2021762	-----	C12, C14, N4C, N5, N6, N6W, SFC, SFE, SFE1, SFE4, SFN1
13	95701-06008-00	BOLT, FLANGE, 6X8.....	3	-----	-----	A1N5, N1F5, N4N5, SFJ
			3	2019699	-----	A1N5/A, A1T5, C14/A, N155, N1B5, N1F5/A, N4N5/A, N6WY, SFE/A, SFE1/A, SFE5, SFL5, SFNR, SFNR/A, T1A5, TBE5
			3	2021762	-----	C12, C14, N4C, N5, N6, N6W, SFC, SFE, SFE1, SFE4, SFN1
			3	2021762	-----	A1N5, N1F5, N4N5, SFJ



E-12

FAN COVER(1)

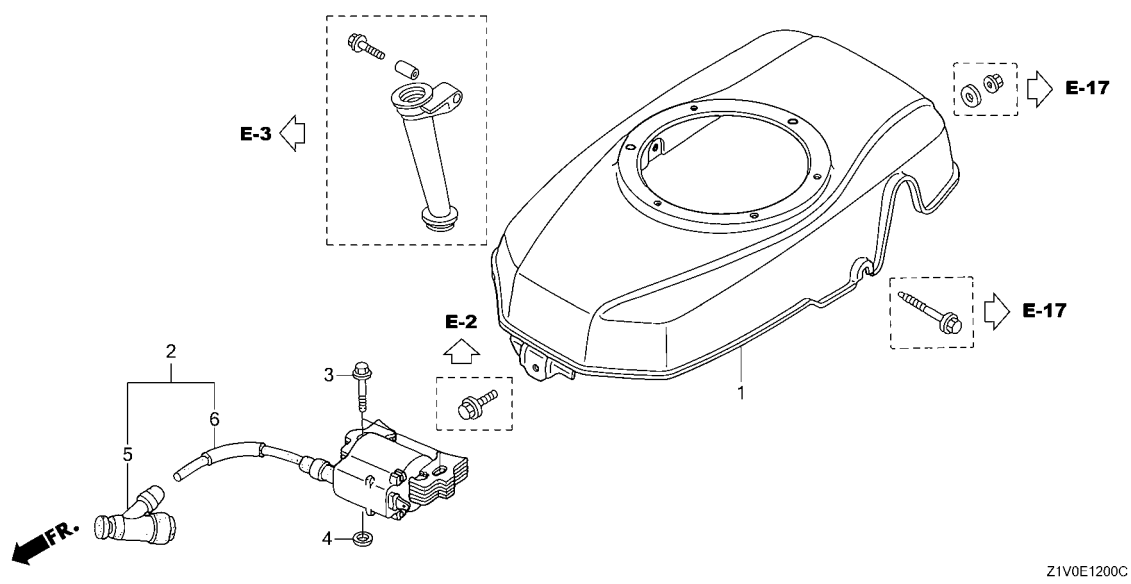

Ref. No.	L.O.N.	(Relative ref. Number) Description	F.R.T.
1	1141G8	COVER, ENGINE COOLING FAN	0.2
2	6141A5	(6) COIL, IGNITION(ONE)	0.2
5	6141B8	TERMINAL, HIGH TENSION	0.1

Ref. No.	Part No.	Description	Reqd. QTY GXV 160 H2	Serial No.	Parts catalogue code	
1	19610-Z1V-000ZB	COVER COMP., FAN *NH1*.....BLACK	1	-----	A14, A1N5, A1S, A1SA, N15, N1F, N1F5, N45, N4N5, N55, N5M, SFE1, SFE4, SFJ, SFL1, SFN1, T1AH	
	19610-Z1V-000ZA	*R280*.....POWER RED	1	-----	A14, A1S, A1SA, C12, C14, N1, N15, N1F, N4, N45, N4C, N5, N55, N5M, N6, N6S, N6W, SFC, SFE, SFE1, SFE4, SFL, SFL1, SFN1, SFNR, SFY, SFY1	
	19610-Z1V-930ZB	*NH1*.....BLACK	1	-----	A1N5/A, N155, N1B5, N1F5/A, N4N5/A, N6WY, SFE/A, SFE1/A, SFE5, SFL5	
	19610-Z1V-930ZA	*R280*.....POWER RED	1	-----	C14/A, N155, SFE/A, SFE1/A, SFE5, SFL5, SFNR/A	
2	30500-Z1V-003	COIL ASSY., IGNITION	1	-----	A14, A1S, A1SA, N1, N15, N1F, N4, N45, N55, N5M, SFL, SFL1, SFY, SFY1, T1AH	
	30100-Z1V-601	COIL ASSY., IGNITION & CAP ASSY., NOISE SUPPRESSOR(TOYO)	1	-----	A1N5/A, C14/A, N155, N1B5, N1F5/A, N4N5/A, N6WY, SFE/A, SFE1/A, SFE5, SFL5, SFNR/A	
	30500-Z1V-003	COIL ASSY., IGNITION	1	1224256	C12, C14, N4C, N5, N6, N6S, SFC	
	30500-Z1V-013	1	2636954	A1N5, N1F5, N4N5, N6W, SFE, SFE1, SFE4, SFJ, SFN1, SFNR	
			1	1224257	N6S	
			1	1224257	N5	
			1	1224257	2636954	C12, C14, N4C, N6, SFC
	30100-Z1V-601	COIL ASSY., IGNITION & CAP ASSY., NOISE SUPPRESSOR(TOYO)	1	2636955	A1N5, C12, C14, N1F5, N4C, N4N5, N6, N6W, SFC, SFE, SFE1, SFE4, SFJ, SFN1, SFNR	
3	90015-883-000	BOLT, FLANGE, 6X28(CT200)	2	-----	A14, A1N5, A1N5/A, A1S, A1SA, C12, C14, C14/A, N1, N15, N155, N1B5, N1F, N1F5, N1F5/A, N4, N45, N4C, N4N5, N4N5/A, N5, N55, N5M, N6, N6S, N6W, N6WY, SFC, SFE, SFE/A, SFE1, SFE1/A, SFE4, SFE5, SFJ, SFL, SFL1, SFL5, SFN1, SFNR, SFNR/A, SFY, SFY1, T1AH	
4	90581-Z1V-000	WASHER, PLAIN, 6MM	2	-----	A14, A1N5, A1N5/A, A1S, A1SA, C12, C14, C14/A, N1, N15, N155, N1B5, N1F, N1F5, N1F5/A, N4, N45, N4C, N4N5, N4N5/A, N5, N55, N5M, N6, N6S, N6W, N6WY, SFC, SFE, SFE/A, SFE1, SFE1/A, SFE4, SFE5, SFJ, SFL, SFL1, SFL5, SFN1, SFNR, SFNR/A, SFY, SFY1, T1AH	
5	30700-Z1V-003	CAP ASSY., NOISE SUPPRESSOR ..	1	-----	A14, A1S, A1SA, N1, N15, N1F, N4, N45, N55, N5M, N6S, SFL, SFL1, SFY, SFY1, T1AH	
	30700-Z1V-601	CAP ASSY., NOISE SUPPRESSOR (TOYO)	1	-----	A1N5/A, C14/A, N155, N1B5, N1F5/A, N4N5/A, N6WY, SFE/A, SFE1/A, SFE5, SFL5, SFNR/A	
	30700-Z1V-003	CAP ASSY., NOISE SUPPRESSOR ..	1	1930185	N5	
			1	2636954	A1N5, C12, C14, N1F5, N4C, N4N5, N6, N6W, SFC, SFE, SFE1, SFE4, SFJ, SFN1, SFNR	
	30700-Z1V-701	1	1930186	N5	

2

E-12

FAN COVER(1)

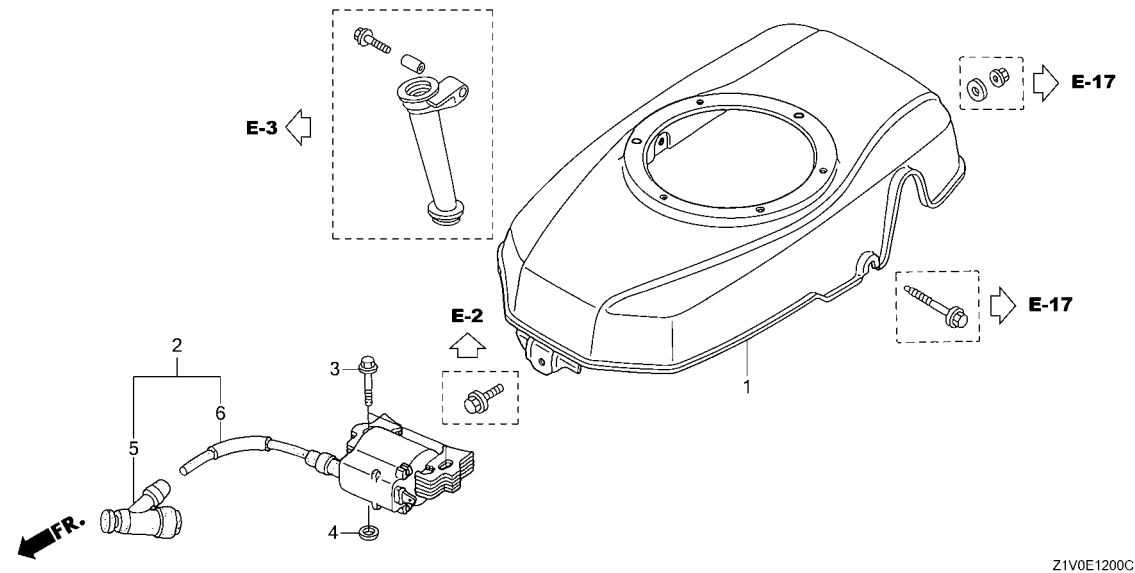

Ref. No.	Part No.	Description	Reqd. QTY		Serial No.	Parts catalogue code
			GXV	H2		
(5)	30700-Z1V-601	CAP ASSY., NOISE SUPPRESSOR (TOYO)	1	2636955	----- A1N5, C12, C14, N1F5, N4C, N4N5, N6, N6W, SFC, SFE, SFE1, SFE4, SFJ, SFN1, SFNR	
6	30500-Z1V-701	COIL ASSY., IGNITION.....	1	1930186	----- N5	

E-12-1

FAN COVER(2)

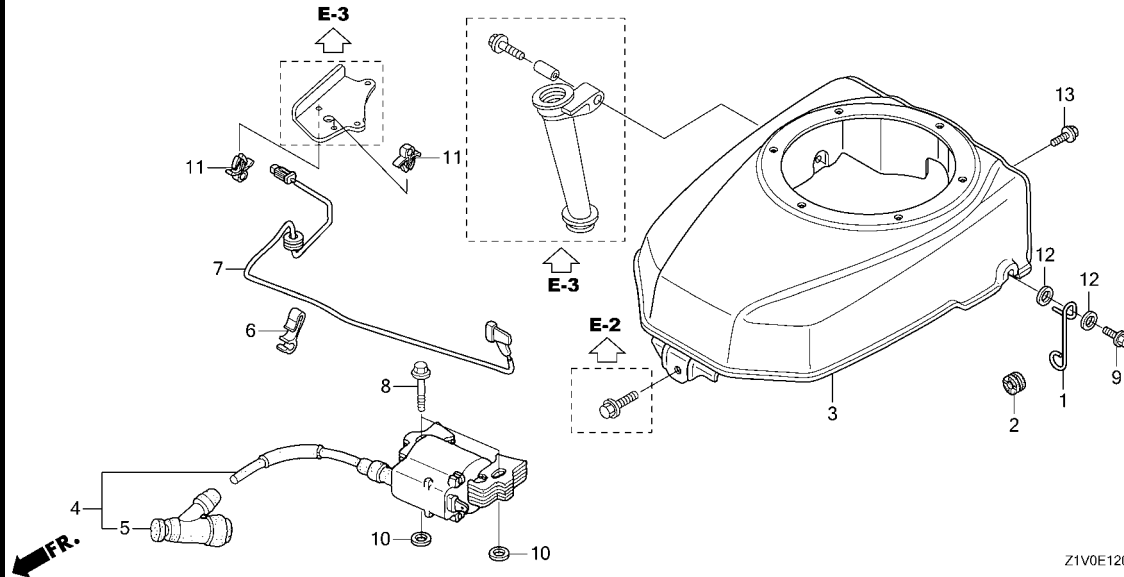

Ref. No.	L.O.N.	(Relative ref. Number) Description	F.R.T.
3	1141G8	COVER, ENGINE COOLING FAN	0.2
4	6141A5	COIL, IGNITION(ONE)	0.2
5	6141B8	TERMINAL, HIGH TENSION	0.1

Ref. No.	Part No.	Description	Reqd. QTY		Serial No.	Parts catalogue code
			GXV	H2		
1	17224-Z4P-800	STAY, FUEL TUBE	1	-----	A1T5, T1A5, TBE5	
2	19051-KA3-830	RUBBER, RADIATOR MOUNTING	1	-----	A1T5, T1A5, TBE5	
3	19610-Z1V-940ZA	COVER COMP., FAN	1	-----	A1T5, T1A5, TBE5	
		R280.....POWER RED	1	-----	A1T5, T1A5, TBE5	
	19610-Z1V-940ZB	*NH1*.....BLACK	1	-----	A1T5, T1A5, TBE5	
4	30100-Z1V-601	COIL ASSY., IGNITION & CAP ASSY., NOISE SUPPRESSOR(TOYO)	1	-----	A1T5, T1A5, TBE5	
5	30700-Z1V-601	CAP ASSY., NOISE SUPPRESSOR (TOYO)	1	-----	A1T5, T1A5, TBE5	
6	32763-PA0-000	CLAMP, CORD	1	-----	TBE5	
7	36101-Z4P-800	CORD, STOP SWITCH	1	-----	TBE5	
8	90015-883-000	BOLT, FLANGE, 6X28(CT200)	2	-----	A1T5, T1A5, TBE5	
9	90029-888-000	BOLT, FLANGE, 6X16(CT200)	1	-----	A1T5, T1A5, TBE5	
10	90581-Z1V-000	WASHER, PLAIN, 6MM	2	-----	A1T5, T1A5, TBE5	
11	90681-959-003	CLIP A, CABLE(NIFCO) (3.8MM BLACK)	2	-----	TBE5	
12	94103-06000	WASHER, PLAIN, 6MM	2	-----	A1T5, T1A5, TBE5	
13	95701-06012-00	BOLT, FLANGE, 6X12	1	-----	A1T5, T1A5, TBE5	

2

E-14

CARBURETOR

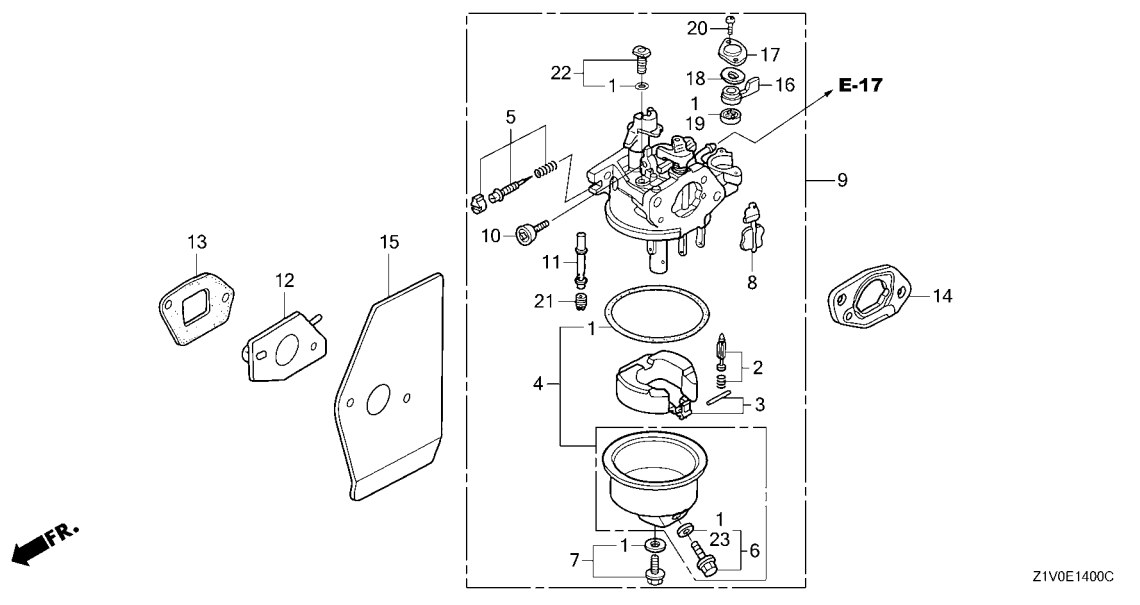

Ref. No.	L.O.N.	(Relative ref. Number) Description	F.R.T.
1	3111B1	GASKET SET, CARBURETOR	0.3
2	3111E1	FLOAT VALVE SET AND/OR FLOAT SET	0.3
5	3111D7	SCREW SET, PILOT	0.2
9	3111F3	CARBURETOR	0.2
12	3111C0	CARBURETOR INSULATOR AND/OR PACKING	0.2
15	3111C8	PACKING, CARBURETOR	0.2
19	3101C5	PACKING, FUEL COCK	0.2
21	3111C3	JET, MAIN	0.3

Ref. No.	Part No.	Description	Reqd. QTY	Serial No.	Parts catalogue code
			GXV 160 H2		
1	16010-ZE0-025	GASKET SET	1	-----	A14, A1N5, A1S, A1SA, C12, C14, N1, N15, N1F, N1F5, N4, N45, N4C, N4N5, N5, N55, N5M, N6, N6S, N6W, SFC, SFE, SFE1, SFE4, SFJ, SFL, SFL1, SFN1, SFNR, SFY, SFY1, T1AH
	16010-Z1T-721	1	-----	A1N5/A, A1T5, C14/A, N155, N1F5/A, N4N5/A, N6WY, SFE/A, SFE1/A, SFE5, SFL5, SFNR/A
	16010-Z4P-WA1	1	-----	T1A5, TBE5
2	16011-ZE0-005	VALVE SET, FLOAT	1	-----	N1B5
3	16013-ZE0-005	FLOAT SET	1	-----	A14, A1S, A1SA, N1, N15, N1F, N4, N45, N55, N5M, SFL, SFL1, SFY, SFY1, T1AH
	16013-Z0S-B01	1	-----	A1N5, A1N5/A, A1T5, C14/A, N155, N1B5, N1F5, N1F5/A, N4C, N4N5, N4N5/A, N6W, N6WY, SFE, SFE/A, SFE1, SFE1/A, SFE4, SFE5, SFJ, SFL5, SFN1, SFNR, SFNR/A, T1A5, TBE5
	16013-ZE0-005	1	-----	
	(CARBURETOR NO.)	1	-----	BE66J A C12, C14, N5, N6, SFC
	16013-Z0S-B01	!!!	1	-----	BE66M A N6S
	(CARBURETOR NO.)	1	-----	
4	16015-ZE0-831	CHAMBER SET, FLOAT	1	-----	C12, C14, N5, N6, N6S, SFC
	16015-Z1T-WA1	1	-----	A14, A1N5, A1S, A1SA, C12, C14, N1, N15, N1F, N1F5, N4, N45, N4C, N4N5, N5, N55, N5M, N6, N6S, N6W, SFC, SFE, SFE1, SFE4, SFJ, SFL, SFL1, SFN1, SFNR, SFY, SFY1, T1AH
	16015-Z4P-WA1	1	-----	A1N5/A, A1T5, C14/A, N155, N1F5/A, N4N5/A, N6WY, SFE/A, SFE1/A, SFE5, SFL5, SFNR/A
5	16016-ZH7-W01	SCREW SET, PILOT	1	-----	T1A5, TBE5
	16016-ZDF-V01	SCREW SET	1	-----	A14, A1N5, A1S, A1SA, A1T5, C12, C14, C14/A, N1, N15, N155, N1B5, N1F, N1F5, N4, N45, N4C, N4N5, N5, N55, N5M, N6, N6S, N6W, SFC, SFE, SFE1, SFE4, SFE5, SFJ, SFL, SFL1, SFL5, SFN1, SFNR, SFNR/A, SFY, SFY1, T1A5, T1AH, TBE5
	16024-ZE1-811	SCREW SET, DRAIN	1	-----	A1N5/A, N1F5/A, N4N5/A, N6WY, SFE/A, SFE1/A
	16024-Z1T-WA1	1	-----	A14, A1N5, A1S, A1SA, C12, C14, N1, N15, N1F, N1F5, N4, N45, N4C, N4N5, N5, N55, N5M, N6, N6S, N6W, SFC, SFE, SFE1, SFE4, SFJ, SFL, SFL1, SFN1, SFNR, SFY, SFY1, T1AH
	16024-ZH7-A20	1	-----	A1N5/A, A1T5, C14/A, N155, N1F5/A, N4N5/A, N6WY, SFE/A, SFE1/A, SFE5, SFL5, SFNR/A
					T1A5, TBE5
					N1B5



E-14

CARBURETOR

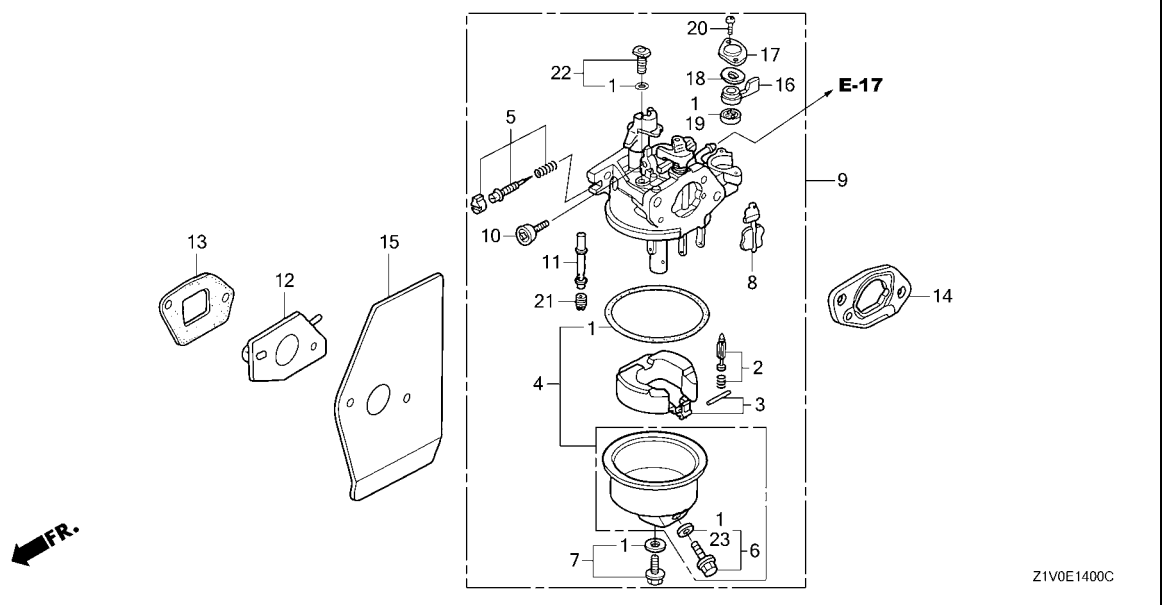

Ref. No.	Part No.	Description	Reqd. QTY		Serial No.	Parts catalogue code
			GXV 160 H2			
7	16028-ZE0-005	SCREW SET	1	-----	-----	A14, A1N5, A1S, A1SA, C12, C14, N1, N15, N1F, N1F5, N4, N45, N4C, N4N5, N5, N55, N5M, N6, N6S, N6W, SFC, SFE, SFE1, SFE4, SFJ, SFL, SFL1, SFN1, SFNR, SFY, SFY1, T1AH
	16028-Z1T-WA1	1	-----	-----	A1N5/A, A1T5, C14/A, N155, N1B5, N1F5/A, N4N5/A, N6WY, SFE/A, SFE1/A, SFE5, SFL5, SFNR/A, T1A5, TBE5
8	16045-ZE7-005	CHOKE SET	1	-----	-----	A14, A1S, A1SA, N1, N15, N1F, N4, N45, N55, N5M, SFL, SFL1, SFY, SFY1, T1AH
	16045-Z1V-G01	1	-----	-----	A1N5, A1T5, C14/A, N155, N1B5, N1F5, N4C, N4N5, N6W, SFE, SFE1, SFE4, SFE5, SFJ, SFL5, SFN1, SFNR, SFNR/A, T1A5, TBE5
	16045-Z1V-WA1	1	-----	-----	A1N5/A, N1F5/A, N4N5/A, N6WY, SFE/A, SFE1/A
	16045-ZE7-005	(CARBURETOR NO.)	1	-----	BE66J A	C12, C14, N5, N6, SFC
	16045-Z1V-G01	!! (CARBURETOR NO.)	1	-----	BE66M A	N6S
	16045-Z1V-G01	!! (CARBURETOR NO.)	1	-----	BE66N A	C12, C14, N5, N6, N6S, SFC
9	16100-Z1V-003	CARBURETOR ASSY. (BE66J A)	1	-----	-----	A14, A1S, A1SA, N1, N15, N1F, N4, N45, N55, SFL, SFL1, SFY, SFY1, T1AH
	16100-Z1V-801	CARBURETOR ASSY. (BE66N A)	1	-----	-----	A1N5, N1F5, N4C, N4N5, N6W, SFE, SFE1, SFE4, SFJ, SFN1, SFNR
	16100-Z4P-WC1	CARBURETOR ASSY. (BEA2T A)	1	-----	-----	A1N5/A, N1F5/A, N4N5/A, N6WY, SFE/A, SFE1/A
	16100-Z1V-831	CARBURETOR ASSY. (BEA2W A)	1	-----	-----	A1T5, N155, SFL5, T1A5, TBE5
	16100-Z1V-802	CARBURETOR ASSY. (BE66N B)	1	-----	-----	C14/A, SFE5, SFNR/A
	16100-Z1V-821	CARBURETOR ASSY. (BEA2Y A)	1	-----	-----	N1B5
	16100-Z1V-J71	CARBURETOR ASSY. (BE66M A)	1	-----	-----	N5M
	16100-Z1V-003	CARBURETOR ASSY. (BE66J A)	1	-----	1095195	C12, C14, N5, N6, SFC
			1	-----	1189960	N6S
	16100-Z1V-801	CARBURETOR ASSY. (BE66N A)	1	-----	1095196	C12, C14, N5, N6, SFC
			1	-----	1189961	N6S
10	16124-ZE0-005	SCREW, THROTTLE STOP	1	-----	-----	
11	16166-Z1V-003	NOZZLE, MAIN	1	-----	-----	A14, A1S, A1SA, N1, N15, N1F, N4, N45, N55, SFL, SFL1, SFY, SFY1, T1AH
	16166-Z1V-801	1	-----	-----	A1N5, A1T5, C14/A, N155, N1B5, N1F5, N4C, N4N5, N6W, SFE, SFE1, SFE4, SFE5, SFJ, SFL5, SFN1, SFNR, SFNR/A, T1A5, TBE5

E-14

CARBURETOR

Ref. No.	Part No.	Description	Reqd. QTY		Serial No.	Parts catalogue code
			GxV 160 H2			
11)	16166-Z4P-WA1	NOZZLE, MAIN	1	-----	-----	A1N5/A,N1F5/A,N4N5/A,N6WY,SFE/A,SFE1/A
	16166-Z1V-J71	1	-----	-----	N5M
	16166-Z1V-003				
		(CARBURETOR NO.)	1	-----	BE66J A	C12,C14,N5,N6,N6S,SFC
	16166-Z1V-J71				
		(CARBURETOR NO.)	1	BE66M A	BE66M A	N6S
	16166-Z1V-801				
		(CARBURETOR NO.)	1	BE66N A	-----	C12,C14,N5,N6,N6S,SFC
12	16211-ZE7-000	INSULATOR, CARBURETOR	1			
13	16212-ZE7-M10	PACKING, INSULATOR	1			
	16212-Z1V-701	PACKING, INSULATOR (NINGBO SIL GASKET)	1	-----	-----	A1N5,A1N5/A,A1T5,C12,C14,C14/A,N155,N1B5,N1F5,N1F5/A,N4C,N4N5,N4N5/A,N5 N6,N6W,N6WY,SFC,SFE,SFE/A,SFE1,SFE1/A,SFE4,SFE5,SFJ,SFL5,SFN1,SFNR,SFNR/A T1A5,TBE5
14	16220-ZE6-010	SPACER COMP., CARBURETOR	1			
15	16221-ZE7-M11	PACKING, CARBURETOR	1			
	16221-Z1V-701	PACKING, CARBURETOR (NINGBO SIL GASKET)	1	-----	-----	A1N5,A1N5/A,A1T5,C12,C14,C14/A,N155,N1B5,N1F5,N1F5/A,N4C,N4N5,N4N5/A,N5 N6,N6W,N6WY,SFC,SFE,SFE/A,SFE1,SFE1/A,SFE4,SFE5,SFJ,SFL5,SFN1,SFNR,SFNR/A T1A5,TBE5
16	16953-ZE1-812	LEVER, COCK	1	-----	-----	A14,A1N5,A1S,A1SA,C12,C14,N1,N15,N1F,N1F5,N4,N45,N4C,N4N5,N5,N55,N5M,N6 N6S,N6W,SFC,SFE,SFE1,SFE4,SFJ,SFL,SFL1,SFN1,SFNR,SFY,SFY1,T1AH
	16953-ZDK-003	1	-----	-----	A1N5/A,A1T5,C14/A,N155,N1B5,N1F5/A,N4N5/A,N6WY,SFE/A,SFE1/A,SFE5,SFL5 SFNR/A,T1A5,TBE5
17	16954-ZE1-812	PLATE, LEVER SETTING	1			
18	16956-ZE1-811	SPRING, COCK LEVER	1			
19	16957-ZE1-812	PACKING, FUEL COCK	1			
20	93500-03006-1H	SCREW, PAN, 3X6	2			
21	99101-ZH8-0620	JET, MAIN, #62	(1)	-----	-----	A14,A1N5,A1S,A1SA,C12,C14,N1,N15,N1F,N1F5,N4,N45,N4C,N4N5,N5,N55,N5M,N6 N6S,N6W,SFC,SFE,SFE1,SFE4,SFJ,SFL,SFL1,SFN1,SFNR,SFY,SFY1,T1AH
	99101-ZH8-0600	JET, MAIN, #60	(1)	-----	-----	A14,A1S,A1SA,N1,N15,N1F,N4,N45,N55,SFL,SFL1,SFY,SFY1,T1AH
	99101-ZH8-0650	JET, MAIN, #65	1	-----	-----	A14,A1S,A1SA,N1,N15,N1F,N4,N45,N55,SFL,SFL1,SFY,SFY1,T1AH
	99101-ZH8-0680	JET, MAIN, #68	(1)	-----	-----	A1N5,N1F5,N4C,N4N5,N5M,N6W,SFE,SFE1,SFE4,SFJ,SFN1,SFNR
	99101-ZDK-0620	JET, MAIN, #62	(1)	-----	-----	A1N5,N1F5,N4C,N4N5,N5M,N6W,SFE,SFE1,SFE4,SFJ,SFN1,SFNR
			(1)	-----	-----	A1N5/A,A1T5,C14/A,N155,N1B5,N1F5/A,N4N5/A,N6WY,SFE/A,SFE1/A,SFE5,SFL5 SFNR/A,T1A5,TBE5
	99101-ZDK-0600	JET, MAIN, #60	(1)	-----	-----	A1N5/A,N1F5/A,N4N5/A,N6WY,SFE/A,SFE1/A
	99101-ZDK-0650	JET, MAIN, #65	1	-----	-----	A1N5/A,N1F5/A,N4N5/A,N6WY,SFE/A,SFE1/A
			(1)	-----	-----	A1T5,C14/A,N155,N1B5,SFE5,SFL5,SFNR/A,T1A5,TBE5
	99101-ZDK-0680	JET, MAIN, #68	1	-----	-----	A1T5,C14/A,N155,N1B5,SFE5,SFL5,SFNR/A,T1A5,TBE5
	99101-ZH8-0600	JET, MAIN, #60	(1)	-----	-----	BE66J A C12,C14,N5,N6,N6S,SFC
	99101-ZH8-0650	JET, MAIN, #65	1	-----	-----	BE66J A C12,C14,N5,N6,N6S,SFC
		(CARBURETOR NO.)	(1)	BE66M A	-----	N6S
	99101-ZH8-0680	JET, MAIN, #68	1	BE66M A	-----	N6S
	99101-ZH8-0650	JET, MAIN, #65	(1)	BE66N A	-----	C12,C14,N5,N6,SFC
	99101-ZH8-0680	JET, MAIN, #68	1	BE66N A	-----	C12,C14,N5,N6,SFC
		(CARBURETOR NO.)	1	-----	-----	A14,A1N5,A1S,A1SA,C12,C14,N1,N15,N1F,N1F5,N4,N45,N4C,N4N5,N5,N55,N5M,N6 N6S,N6W,SFC,SFE,SFE1,SFE4,SFJ,SFL,SFL1,SFN1,SFNR,SFY,SFY1,T1AH
22	99204-ZE0-0350	JET SET, PILOT, #35	1	-----	-----	A1N5/A,N1F5/A,N4N5/A,N6WY,SFE/A,SFE1/A
	99204-ZE2-0400	JET SET, PILOT, #40	1	-----	-----	A1N5/A,N1F5/A,N4N5/A,N6WY,SFE/A,SFE1/A
	99204-ZE2-0350	JET SET, PILOT, #35	1	-----	-----	A1T5,C14/A,N155,N1B5,SFE5,SFL5,SFNR/A,T1A5,TBE5
23	16141-Z0S-003	WASHER, PLAIN(6.2X10.7 DRAIN)	1	-----	-----	A1N5,A1N5/A,A1T5,C12,C14,C14/A,N155,N1F5,N1F5/A,N4C,N4N5,N4N5/A,N5,N6,N6W N6WY,SFC,SFE,SFE/A,SFE1,SFE1/A,SFE4,SFE5,SFJ,SFL5,SFN1,SFNR,SFNR/A,T1A5 TBE5



E-15

AIR CLEANER

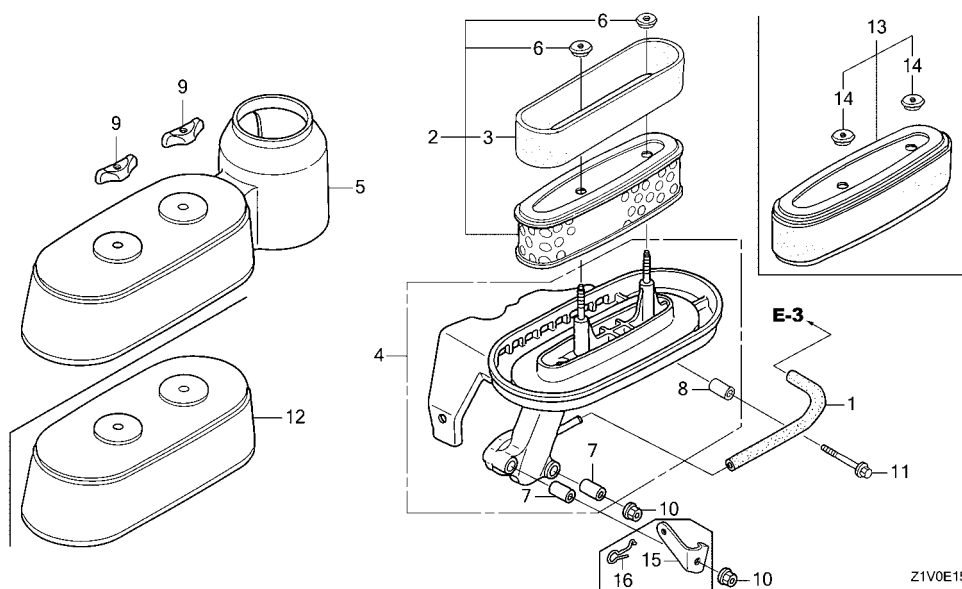

Ref. No.	L.O.N.	(Relative ref. Number) Description	F.R.T.
1	1111K5	TUBE, BREATHER	0.1
2	3121B8	ELEMENT, AIR CLEANER	0.1
3	3121C1	FILTER, OUTER	0.1
4	3121A5	CASE, AIR CLEANER	0.2
5	3121B1	COVER, AIR CLEANER	0.1

FR. ←

Ref. No.	Part No.	Description	Reqd. QTY	Serial No.	Parts catalogue code
			GXV 160 H2		
1	15721-ZE7-000	TUBE, BREATHER	1		
2	17210-Z1V-003	ELEMENT, AIR CLEANER	1		A14, A1N5, A1N5/A, A1S, A1SA, A1T5, N1, N15, N155, N1B5, N1F, N1F5, N1F5/A, N4, N45, N4N5, N4N5/A, N5, N55, N5M, N6, N6S, N6W, N6WY, SFE, SFE/A, SFE1, SFE1/A, SFE4, SFE5, SFJ, SFL, SFL1, SFL5, SFN1, SFNR, SFNR/A, SFY, SFY1, T1A5, T1AH, TBE5
3	17218-888-003	FILTER, OUTER	1	1794764	C12, C14, N4C, SFC
4	17220-Z1V-000	CASE COMP., AIR CLEANER	1	1794764	A14, A1S, A1SA, N1, N15, N1F, N4, N45, N55, N5M, N6S, SFL, SFL1, SFY, SFY1, T1AH
	17220-Z1V-010	1		A1N5/A, A1T5, N155, N1B5, N1F5/A, N4N5/A, N6WY, SFE/A, SFE1/A, SFE5, SFL5, SFNR, SFNR/A, T1A5, TBE5
	17220-Z1V-602	1		C14/A
	17220-Z1V-000	1	1794764	C12, C14, N4C, SFC
		1	1962168	A1N5, N1F5, N4N5, SFE, SFE1, SFE4, SFN1
		1	1965377	N5, N6, N6W, SFJ
	17220-Z1V-601	1	1794765	C12, C14, N4C, SFC
	17220-Z1V-602	1	1956261	C12, C14, N4C, SFC
	17220-Z1V-010	1	1962169	A1N5, N1F5, N4N5, SFE, SFE1, SFE4, SFN1
		1	1965378	N5, N6, N6W, SFJ
5	17231-Z1V-000	COVER, AIR CLEANER	1		A14, A1S, A1SA, N1, N15, N1F, N4, N45, N5, N55, N5M, N6, N6S, N6W, N6WY, SFJ, SFL, SFL1, SFY, SFY1, T1AH
	17231-Z1V-601	1		C14/A
	17231-Z1V-000	1	1794764	C12, C14, N4C, SFC
	17231-Z1V-601	1	1794765	C12, C14, N4C, SFC

E-15

AIR CLEANER

Ref. No.	Part No.	Description	Reqd. QTY		Serial No.	Parts catalogue code
			GXV 160 H2			
6	17232-891-000	GROMMET, AIR CLEANER.....	2	-----	-----	A14, A1N5, A1N5/A, A1S, A1SA, A1T5, N1, N15, N155, N1B5, N1F, N1F5, N1F5/A, N4, N45, N4N5, N4N5/A, N5, N55, N5M, N6, N6S, N6W, N6WY, SFE, SFE/A, SFE1, SFE1/A, SFE4, SFE5, SFJ, SFL, SFL1, SFL5, SFN1, SFNR, SFNR/A, SFY, SFY1, T1A5, T1AH, TBE5
7	17238-ZE7-710	COLLAR, AIR CLEANER.....	2	-----	1794764	C12, C14, N4C, SFC
	17238-Z1V-601	2	-----	-----	A14, A1N5, A1N5/A, A1S, A1SA, A1T5, N1, N15, N155, N1B5, N1F, N1F5, N1F5/A, N4, N45, N4N5, N4N5/A, N5, N55, N5M, N6, N6S, N6W, N6WY, SFE, SFE/A, SFE1, SFE1/A, SFE4, SFE5, SFJ, SFL, SFL1, SFL5, SFN1, SFNR, SFNR/A, SFY, SFY1, T1A5, T1AH, TBE5
	17238-ZE7-710	2	-----	1794764	C14/A
	17238-Z1V-601	2	-----	1794765	C12, C14, N4C, SFC
8	17239-ZE6-300	COLLAR B, AIR CLEANER.....	1	-----	-----	A14, A1N5, A1N5/A, A1S, A1SA, A1T5, N1, N15, N155, N1B5, N1F, N1F5, N1F5/A, N4, N45, N4N5, N4N5/A, N5, N55, N5M, N6, N6S, N6W, N6WY, SFE, SFE/A, SFE1, SFE1/A, SFE4, SFE5, SFJ, SFL, SFL1, SFL5, SFN1, SFNR, SFNR/A, SFY, SFY1, T1A5, T1AH, TBE5
	17239-Z1V-601	1	-----	-----	C14/A
	17239-ZE6-300	1	-----	1794764	C12, C14, N4C, SFC
	17239-Z1V-601	1	-----	1794765	C12, C14, N4C, SFC
9	90300-Z1V-000	NUT, AIR CLEANER.....	2	-----	-----	A14, A1N5, A1N5/A, A1S, A1SA, A1T5, N1, N15, N155, N1B5, N1F, N1F5, N1F5/A, N4, N45, N4N5, N4N5/A, N5, N55, N5M, N6, N6S, N6W, N6WY, SFE, SFE/A, SFE1, SFE1/A, SFE4, SFE5, SFJ, SFL, SFL1, SFL5, SFN1, SFNR, SFNR/A, SFY, SFY1, T1A5, T1AH, TBE5
	90201-Z1V-601	2	-----	-----	C14/A
	90300-Z1V-000	2	-----	1794764	C12, C14, N4C, SFC
	90201-Z1V-601	2	-----	1794765	C12, C14, N4C, SFC
10	94050-06000	NUT, FLANGE, 6MM.....	2	-----	-----	C12, C14, N4C, SFC
11	95701-06035-00	BOLT, FLANGE, 6X35.....	1	-----	-----	
12	17231-Z1V-601	COVER, AIR CLEANER.....	1	-----	-----	A1N5, A1N5/A, A1T5, N155, N1B5, N1F5, N1F5/A, N4N5, N4N5/A, SFE, SFE/A, SFE1, SFE1/A, SFE4, SFE5, SFL5, SFN1, SFNR, SFNR/A, T1A5, TBE5
13	17210-Z1V-601	ELEMENT, AIR CLEANER.....	1	-----	-----	C14/A
		1	-----	1794765	C12, C14, N4C, SFC
14	17232-Z1V-601	GROMMET, AIR CLEANER.....	2	-----	-----	C14/A
		2	-----	1794765	C12, C14, N4C, SFC
15	16598-Z1V-G00	STAY, CHOKE CONTROL.....	1	-----	-----	TBE5
16	16611-Z1V-G00	ROD, CHOKE CONTROL.....	1	-----	-----	TBE5



E-16

MUFFLER

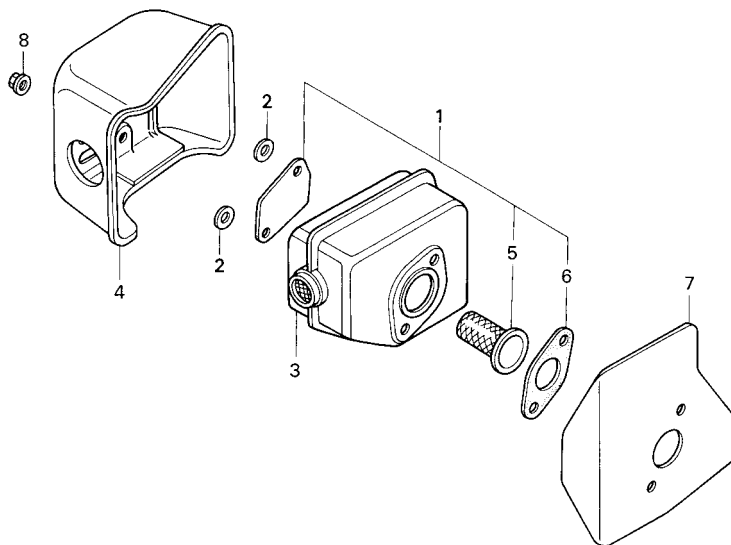

Z1V0-E1600

Ref. No.	L.O.N.	(Relative ref. Number) Description	F.R.T.
1	3131A0	ARRESTER KIT, SPARK	0.2
3	3131C5	MUFFLER, EXHAUST	0.2
4	3131D6	PROTECTOR, EXHAUST MUFFLER ...	0.1
5	3131A1	ARRESTER, SPARK	0.2
6	3131B4	GASKET, EXHAUST MUFFLER	0.2

Ref. No.	Part No.	Description	Reqd. QTY	Serial No.	Parts catalogue code
			GXV 160 H2		
1	06180-ZE6-820	ARRESTER KIT, SPARK	(1)		
2	18292-ZE7-M10	PACKING, PROTECTOR	2		A14, A1N5, A1N5/A, A1S, A1SA, C12, C14, C14/A, N15, N155, N1B5, N1F, N1F5, N1F5/A, N4, N45, N4C, N4N5, N4N5/A, N55, N5M, SFC, SFE, SFE/A, SFE1, SFE1/A, SFE4, SFE5, SFJ, SFL5, SFN1, SFNR, SFNR/A, SFY
3	18310-Z1V-000	MUFFLER COMP.	2	1003408	SFL, SFL1, SFY1
	18310-Z1V-010	1		A14, A1S, A1SA, N1, N15, N1F, N4, N45, N55, N5M, N6S, SFL, SFL1, SFY, SFY1, T1AH
	18310-Z1V-000	1		A1N5/A, A1T5, C14/A, N155, N1B5, N1F5/A, N4N5/A, N6WY, SFE/A, SFE1/A, SFE5, SFL5, SFNR, SFNR/A, T1A5, TBE5
	18310-Z1V-000	1	1967027	A1N5, C12, C14, N1F5, N4C, N4N5, N5, N6, N6W, SFC, SFE, SFE1, SFE4, SFJ, SFN1
	18310-Z1V-010	1	1967028	A1N5, C12, C14, N1F5, N4C, N4N5, N5, N6, N6W, SFC, SFE, SFE1, SFE4, SFJ, SFN1
4	18320-Z1V-000	PROTECTOR COMP., MUFFLER	1		A14, A1S, A1SA, N1, N15, N1F, N4, N45, N55, N5M, SFL, SFL1, SFY, SFY1, T1AH
	18320-Z1V-010	1		A1N5, A1N5/A, A1T5, C12, C14, C14/A, N155, N1B5, N1F5, N1F5/A, N4C, N4N5, N4N5/A, N5, N6, N6S, N6W, N6WY, SFC, SFE, SFE/A, SFE1, SFE1/A, SFE4, SFE5, SFJ, SFL5, SFN1, SFNR, SFNR/A, T1A5, TBE5
5	18355-888-810	ARRESTER, SPARK	(1)		
6	18381-ZE6-820	GASKET, MUFFLER	(1)		
	18382-Z1V-701	GASKET, MUFFLER (NINGBO SIL GASKET)	1		SFJ
7	18381-Z1V-000	GASKET, MUFFLER	1		
8	90343-ZE6-000	NUT, SELF-LOCK, 6MM	2		

E-17

FUEL TANK

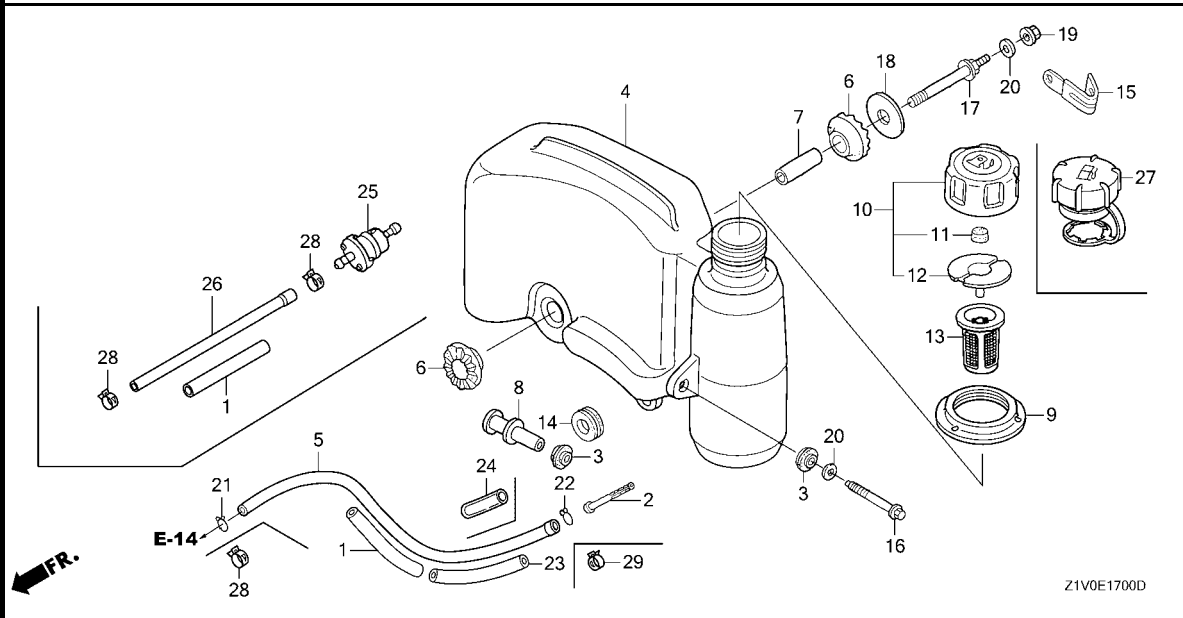

Ref. No.	L.O.N.	(Relative ref. Number) Description	F.R.T.
2	3101H8	STRAINER, FUEL	0.2
4	3101H7	TANK, FUEL	0.2
5	3101F6	TUBE, FUEL	0.1
6	3101M0	RUBBER B, TANK MOUNTING	0.2
12	3101L9	PACKING, FUEL CAP	0.1
13	3101M1	GAUGE, FUEL LEVEL	0.1

Z1V0E1700D

Ref. No.	Part No.	Description	Reqd. QTY GXV 160 H2	Serial No.	Parts catalogue code
1	16854-ZH8-000	RUBBER, SUPPORTER(107MM).....	1		
2	16952-Z1V-000	STRAINER, FUEL	1	-----	A14, A1N5, A1N5/A, A1S, A1SA, C12, C14, C14/A, N1, N15, N155, N1B5, N1F, N1F5, N1F5/A, N4, N45, N4C, N4N5, N4N5/A, N5, N55, N5M, N6, N6S, N6W, N6WY, SFC, SFE, SFE/A, SFE1, SFE1/A, SFE4, SFE5, SFJ, SFL, SFL1, SFL5, SFN1, SFNR, SFNR/A, SFY, SFY1, T1AH
3	17506-ZE7-000	RUBBER, TANK SETTING.....	2	-----	A14, A1N5, A1N5/A, A1S, A1SA, C12, C14, C14/A, N1, N15, N155, N1B5, N1F, N1F5, N1F5/A, N4, N45, N4C, N4N5, N4N5/A, N5, N55, N5M, N6, N6S, N6W, N6WY, SFC, SFE, SFE/A, SFE1, SFE1/A, SFE4, SFE5, SFJ, SFL, SFL1, SFL5, SFN1, SFNR, SFNR/A, SFY, SFY1, T1AH
4	17510-Z1V-010	TANK COMP., FUEL	1	-----	A14, A1N5, A1N5/A, A1S, A1SA, C12, C14, C14/A, N1, N15, N1F, N1F5, N1F5/A, N4, N45, N4C, N4N5, N4N5/A, N5, N55, N5M, N6, N6S, N6W, N6WY, SFC, SFE, SFE/A, SFE1, SFE1/A, SFE4, SFE5, SFJ, SFL, SFL1, SFN1, SFNR, SFNR/A, SFY, SFY1, T1AH
	17510-Z4P-810	1	-----	N155, N1B5, SFL5
5	17512-ZE7-000	TUBE, FUEL	1	-----	A14, A1S, A1SA, N1, N15, N1F, N4, N45, N55, N5M, SFL, SFL1, SFY, SFY1, T1AH
	17512-ZE7-010	1	-----	A1N5, A1N5/A, C14/A, N1F5, N1F5/A, N4N5, N4N5/A, N6W, N6WY, SFE, SFE/A, SFE1, SFE1/A, SFE4, SFE5, SFJ, SFL, SFN1, SFNR, SFNR/A
	17512-Z4P-811	TUBE, FUEL(FKM)	1	-----	N155, N1B5, SFL5
	17512-ZE7-000	TUBE, FUEL	1	1276790	C12, C14, N4C, N5, N6, N6S, SFC
	17512-ZE7-010	1	1276791	C12, C14, N4C, N5, N6, N6S, SFC
6	17516-896-700	RUBBER B, TANK MOUNTING.....	2	-----	A14, A1N5, A1N5/A, A1S, A1SA, C12, C14, C14/A, N1, N15, N155, N1B5, N1F, N1F5, N1F5/A, N4, N45, N4C, N4N5, N4N5/A, N5, N55, N5M, N6, N6S, N6W, N6WY, SFC, SFE, SFE/A, SFE1, SFE1/A, SFE4, SFE5, SFJ, SFL, SFL1, SFL5, SFN1, SFNR, SFNR/A, SFY, SFY1, T1AH
7	17518-Z1V-000	COLLAR, TANK SET.....	1	-----	A14, A1N5, A1N5/A, A1S, A1SA, C12, C14, C14/A, N1, N15, N155, N1B5, N1F, N1F5, N1F5/A, N4, N45, N4C, N4N5, N4N5/A, N5, N55, N5M, N6, N6S, N6W, N6WY, SFC, SFE, SFE/A, SFE1, SFE1/A, SFE4, SFE5, SFJ, SFL, SFL1, SFL5, SFN1, SFNR, SFNR/A, SFY, SFY1, T1AH
8	17519-Z1V-000	COLLAR COMP., TANK.....	1	-----	A14, A1N5, A1N5/A, A1S, A1SA, C12, C14, C14/A, N1, N15, N155, N1B5, N1F, N1F5, N1F5/A, N4, N45, N4C, N4N5, N4N5/A, N5, N55, N5M, N6, N6S, N6W, N6WY, SFC, SFE, SFE/A, SFE1, SFE1/A, SFE4, SFE5, SFJ, SFL, SFL1, SFL5, SFN1, SFNR, SFNR/A, SFY, SFY1, T1AH
9	17532-Z1V-000	RUBBER, TANK MOUNTING.....	1	-----	A14, A1S, A1SA, C12, C14, C14/A, N1, N15, N1F, N4, N45, N4C, N5, N55, N5M, N6, N6S, N6W, N6WY, SFC, SFJ, SFL, SFL1, SFY, SFY1, T1AH



E-17

FUEL TANK

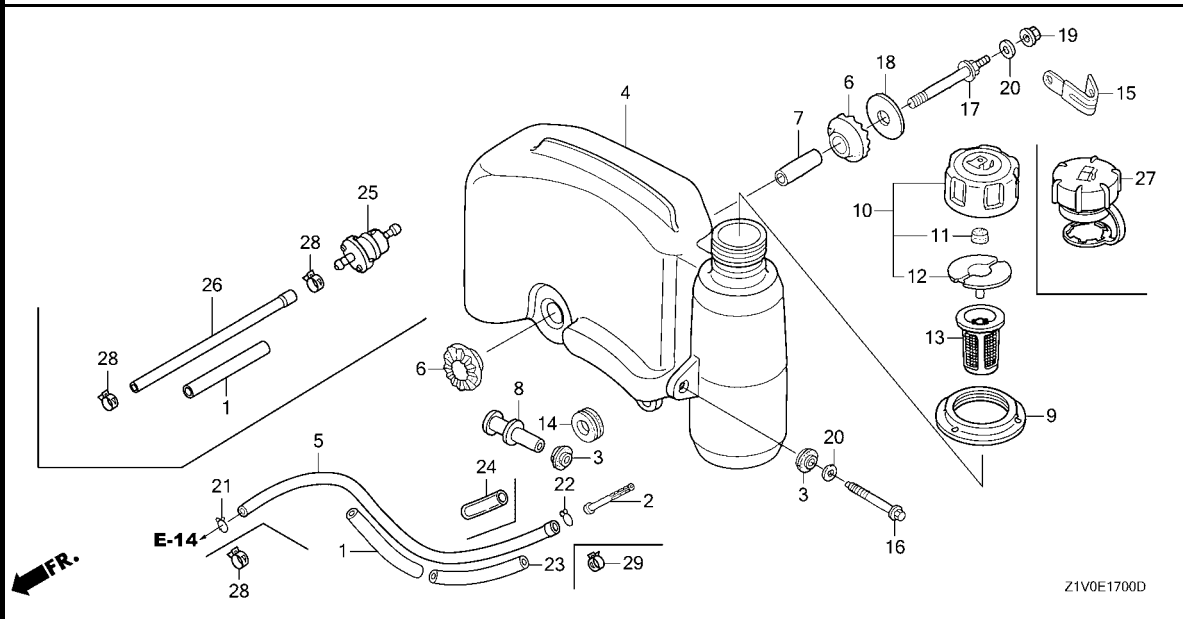

Ref. No.	Part No.	Description	Reqd. QTY GXV 160 H2	Serial No.	Parts catalogue code
10	17620-Z1V-000	CAP ASSY., FUEL TANK.....	1	-----	A14, A1N5, A1N5/A, A1S, A1SA, C12, C14, C14/A, N1, N15, N1F, N1F5, N1F5/A, N4, N45, N4C, N4N5, N4N5/A, N5, N55, N5M, N6, N6S, N6W, N6WY, SFC, SFE, SFE/A, SFE1, SFE1/A, SFE4, SFE5, SFJ, SFL, SFL1, SFN1, SFNR, SFNR/A, SFY, SFY1, T1AH
11	17622-888-010	SPONGE, FUEL CAP BREATHER....	1	-----	A14, A1N5, A1N5/A, A1S, A1SA, C12, C14, C14/A, N1, N15, N1F, N1F5, N1F5/A, N4, N45, N4C, N4N5, N4N5/A, N5, N55, N5M, N6, N6S, N6W, N6WY, SFC, SFE, SFE/A, SFE1, SFE1/A, SFE4, SFE5, SFJ, SFL, SFL1, SFN1, SFNR, SFNR/A, SFY, SFY1, T1AH
12	17624-ZE7-000	PACKING, FUEL CAP.....	1	-----	A14, A1N5, A1N5/A, A1S, A1SA, C12, C14, C14/A, N1, N15, N1F, N1F5, N1F5/A, N4, N45, N4C, N4N5, N4N5/A, N5, N55, N5M, N6, N6S, N6W, N6WY, SFC, SFE, SFE/A, SFE1, SFE1/A, SFE4, SFE5, SFJ, SFL, SFL1, SFN1, SFNR, SFNR/A, SFY, SFY1, T1AH
13	17636-Z1V-010	GAUGE, FUEL LEVEL.....	1	-----	A14, A1N5, A1N5/A, A1S, A1SA, C12, C14, C14/A, N1, N15, N155, N1B5, N1F, N1F5, N1F5/A, N4, N45, N4C, N4N5, N4N5/A, N5, N55, N5M, N6, N6S, N6W, N6WY, SFC, SFE, SFE/A, SFE1, SFE1/A, SFE4, SFE5, SFJ, SFL, SFL1, SFL5, SFN1, SFNR, SFNR/A, SFY, SFY1, T1AH
14	80103-MG2-000	CUSHION, RR. FENDER.....	1	-----	A14, A1N5, A1N5/A, A1S, A1SA, C12, C14, C14/A, N1, N15, N155, N1B5, N1F, N1F5, N1F5/A, N4, N45, N4C, N4N5, N4N5/A, N5, N55, N5M, N6, N6S, N6W, N6WY, SFC, SFE, SFE/A, SFE1, SFE1/A, SFE4, SFE5, SFJ, SFL, SFL1, SFL5, SFN1, SFNR, SFNR/A, SFY, SFY1, T1AH
15	90010-GE0-710	CLIP, TUBE.....	1	-----	A14, A1S
	90010-Z1V-800	1	-----	A1N5, A1N5/A, C14/A
	90010-GE0-710	1	1494275	C12, C14, SFC
	90010-Z1V-800	1	1494276	C12, C14, SFC
16	90014-Z1V-000	BOLT, FLANGE, 6X47(CT200)....	1	-----	A14, A1N5, A1N5/A, A1S, A1SA, C12, C14, C14/A, N1, N15, N155, N1B5, N1F, N1F5, N1F5/A, N4, N45, N4C, N4N5, N4N5/A, N5, N55, N5M, N6, N6S, N6W, N6WY, SFC, SFE, SFE/A, SFE1, SFE1/A, SFE4, SFE5, SFJ, SFL, SFL1, SFL5, SFN1, SFNR, SFNR/A, SFY, SFY1, T1AH
17	90016-Z1V-000	BOLT, TANK STAY.....	1	-----	A14, A1N5, A1N5/A, A1S, A1SA, C12, C14, C14/A, N1, N15, N155, N1B5, N1F, N1F5, N1F5/A, N4, N45, N4C, N4N5, N4N5/A, N5, N55, N5M, N6, N6S, N6W, N6WY, SFC, SFE, SFE/A, SFE1, SFE1/A, SFE4, SFE5, SFJ, SFL, SFL1, SFL5, SFN1, SFNR, SFNR/A, SFY, SFY1, T1AH



E-17

FUEL TANK

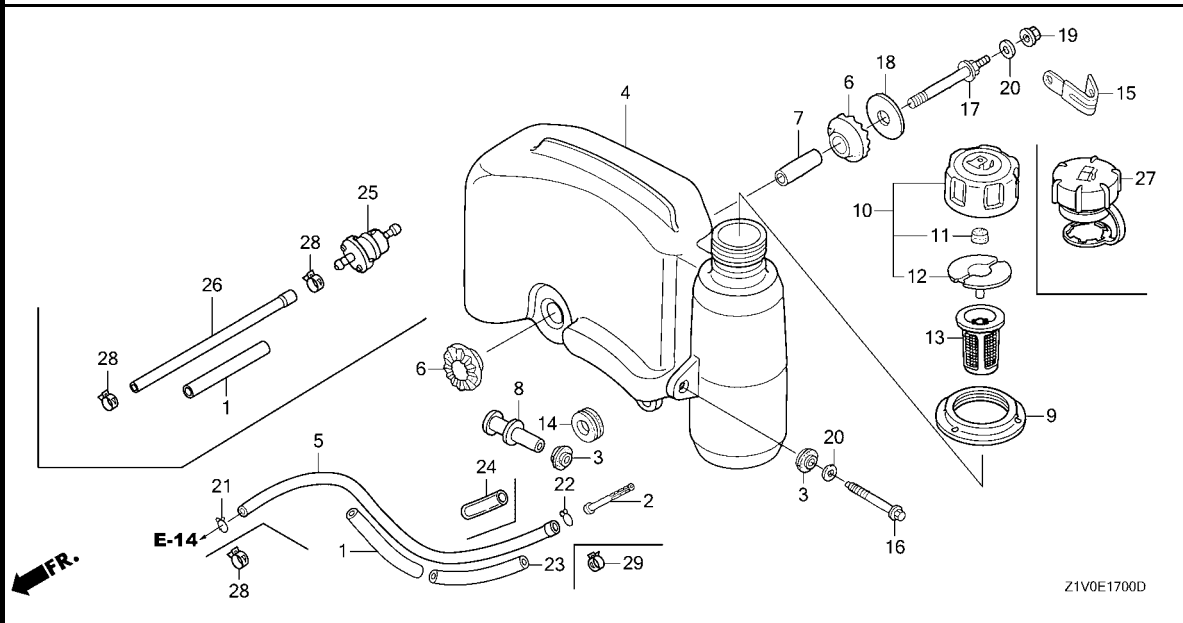

Ref. No.	Part No.	Description	Reqd. QTY GXV 160 H2	Serial No.	Parts catalogue code
18	90455-896-700	WASHER, TANK MOUNTING	1	-----	A14, A1N5, A1N5/A, A1S, A1SA, C12, C14, C14/A, N1, N15, N155, N1B5, N1F, N1F5, N1F5/A, N4, N45, N4C, N4N5, N4N5/A, N5, N55, N5M, N6, N6S, N6W, N6WY, SFC, SFE, SFE/A, SFE1, SFE1/A, SFE4, SFE5, SFJ, SFL, SFL1, SFL5, SFN1, SFNR, SFNR/A, SFY, SFY1, T1AH
19	94050-06000	NUT, FLANGE, 6MM	1	-----	A14, A1N5, A1N5/A, A1S, A1SA, C12, C14, C14/A, N1, N15, N155, N1B5, N1F, N1F5, N1F5/A, N4, N45, N4C, N4N5, N4N5/A, N5, N55, N5M, N6, N6S, N6W, N6WY, SFC, SFE, SFE/A, SFE1, SFE1/A, SFE4, SFE5, SFJ, SFL, SFL1, SFL5, SFN1, SFNR, SFNR/A, SFY, SFY1, T1AH
20	94103-06000	WASHER, PLAIN, 6MM	2	-----	A14, A1N5, A1N5/A, A1S, A1SA, C12, C14, C14/A, N1, N15, N155, N1B5, N1F, N1F5, N1F5/A, N4, N45, N4C, N4N5, N4N5/A, N5, N55, N5M, N6, N6S, N6W, N6WY, SFC, SFE, SFE/A, SFE1, SFE1/A, SFE4, SFE5, SFJ, SFL, SFL1, SFL5, SFN1, SFNR, SFNR/A, SFY, SFY1, T1AH
21	95002-02080	CLIP, TUBE(B8)	1	-----	A14, A1N5, A1N5/A, A1S, A1SA, C12, C14, C14/A, N1, N15, N1F, N1F5, N1F5/A, N4, N45, N4C, N4N5, N4N5/A, N5, N55, N5M, N6, N6S, N6W, N6WY, SFC, SFE, SFE/A, SFE1, SFE1/A, SFE4, SFE5, SFJ, SFL, SFL1, SFN1, SFNR, SFNR/A, SFY, SFY1, T1AH
22	95002-70000	CLIP, TUBE(C11)	1	-----	A14, A1N5, A1N5/A, A1S, A1SA, C12, C14, C14/A, N1, N15, N1F, N1F5, N1F5/A, N4, N45, N4C, N4N5, N4N5/A, N5, N55, N5M, N6, N6S, N6W, N6WY, SFC, SFE, SFE/A, SFE1, SFE1/A, SFE4, SFE5, SFJ, SFL, SFL1, SFN1, SFNR, SFNR/A, SFY, SFY1, T1AH
23	16854-ZH8-000	RUBBER, SUPPORTER(107MM)	1	-----	A14, A1S, A1SA, N1, N15, N1F, N4, N45, N55, N5M, SFL, SFL1, SFY, SFY1, T1AH
24	95003-25003-20	TUBE, VINYL, 9X11X30 (95003-25001-10M)	1	1276790	C12, C14, N4C, N5, N6, N6S, SFC
25	16910-ZE8-015	STRAINER COMP., FUEL	1	-----	A1N5, A1N5/A, C14/A, N155, N1B5, N1F5, N1F5/A, N4N5, N4N5/A, N6W, N6WY, SFE, SFE/A, SFE1, SFE1/A, SFE4, SFE5, SFJ, SFL5, SFN1, SFNR, SFNR/A
26	91424-ZBC-801	TUBE, FUEL, 4.2X210(FKM)	1	-----	A1T5, T1A5, TBE5
27	17620-Z0J-800	CAP ASSY., FUEL TANK	1	-----	N155, N1B5, SFL5
28	95002-40800-08	CLAMP, TUBE(D8)	2	-----	A1T5, T1A5, TBE5
			1	-----	N155, N1B5, SFL5
29	95002-41050-08	CLAMP, TUBE(D10.5)	1	-----	N155, N1B5, SFL5



E-19

FLYWHEEL(1)

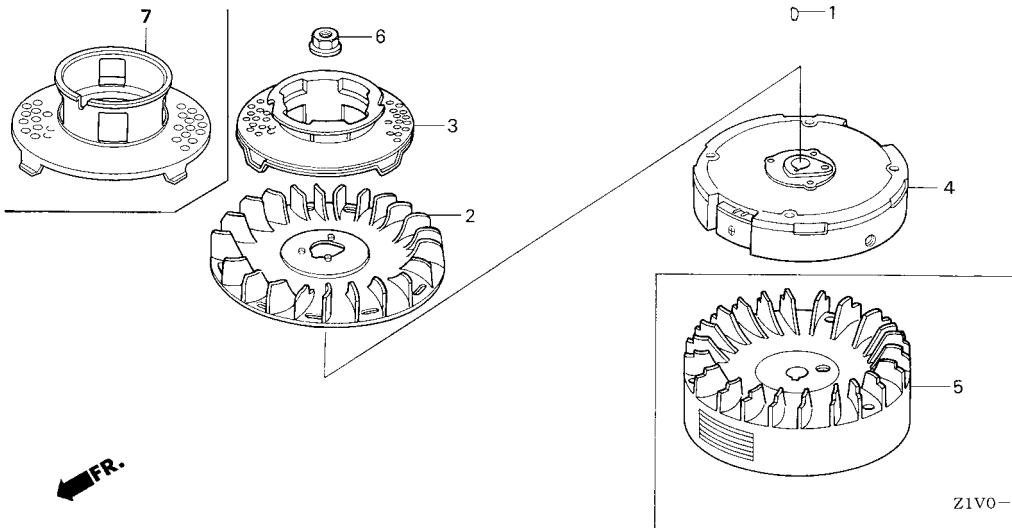

Ref. No.	L.O.N.	(Relative ref. Number) Description	F.R.T.
2	1141G7	FAN, ENGINE COOLING	0.2
3		(7)	
	1121A9	PULLEY, RECOIL STARTER	0.2
4		(5)	
	2161B5	FLYWHEEL	0.3

Ref. No.	Part No.	Description	Reqd. QTY GXV 160 H2	Serial No.	Parts catalogue code
1	13331-357-000 13331-Z8B-900	KEY, SPECIAL WOODRUFF, 25X18	1	-----	N1,N15,N1F,N4,N45,N55,N5M,N6S,SFE4,SFL,SFL1,SFY,SFY1,T1AH
2	19511-Z1T-000	FAN, COOLING	1	-----	N155,N1B5,N1F5,N1F5/A,N4C,N4N5,N4N5/A,N5,N6,N6W,N6WY,SFE,SFE/A,SFE1 SFE1/A,SFE5,SFJ,SFL5,SFN1,SFNR,SFNR/A,T1A5,TBE5
3	28450-Z1V-930 28450-Z1V-700 28451-ZE7-003	PULLEY COMP., STARTER	1	-----	N1B5,N1F,N1F5,N1F5/A,N5M,N6S,SFE,SFE/A,SFE1,SFE1/A,SFE4,SFE5,SFJ,SFL,SFL1 SFL5,SFN1,SFNR,SFNR/A,SFY,SFY1,T1A5,TBE5
			1	-----	N155,N1B5,N1F5/A,N4N5/A,N6WY,SFE/A,SFE1/A,SFE5,SFL5,SFNR/A,T1A5,TBE5 SFNR
			1	1098141	N15,N1F,N45,N55,N5M
			1	1113862	N1,N4,N5,N6,N6S,SFL,SFL1,SFY,SFY1,T1AH
	28450-Z1V-700		1	1915343	N4C,N5,N6,N6W,SFE,SFE1,SFE4,SFN1
			1	1916288	N1F5,N4N5,SFJ
4	31110-Z1V-003	FLYWHEEL COMP.(MAHLE)	1	-----	N1B5,N1F,N1F5,N1F5/A,N5M,N6S,SFE,SFE/A,SFE1,SFE1/A,SFE4,SFE5,SFJ,SFL,SFL1 SFL5,SFN1,SFNR,SFNR/A,SFY,SFY1,T1A5,TBE5
5	31110-Z1V-810 31110-Z1V-811 31110-Z1V-810 31110-Z1V-811	FLYWHEEL COMP.(BRAKE)	1	-----	N1,N15,N4,N45,N55,T1AH
			1	-----	N155,N4N5,N4N5/A,N6WY
			1	1770423	N4C,N5,N6,N6W
			1	1770424	N4C,N5,N6,N6W
6	90201-Z1T-000	NUT, SPECIAL, 14MM	1	-----	N1,N15,N155,N1B5,N1F,N1F5,N1F5/A,N4,N45,N4C,N4N5,N4N5/A,N5,N55,N5M,N6,N6S N6W,N6WY,SFE,SFE/A,SFE1,SFE1/A,SFE4,SFE5,SFJ,SFL,SFL1,SFL5,SFN1,SFNR SFNR/A,SFY,SFY1,T1A5,T1AH,TBE5
7	28450-Z1V-000	PULLEY COMP., STARTER	1	1915342	N4C,N6W,SFE,SFE1,SFE4,SFN1
			1	1916287	N1F5,N4N5,SFJ
			1	1098142	N15,N1F,N45,N55,N5M
			1	1113863	N1,N4,N6S,SFL,SFL1,SFY,SFY1,T1AH
			1	1113863	1915342 N5,N6

E-19-1

FLYWHEEL(2)

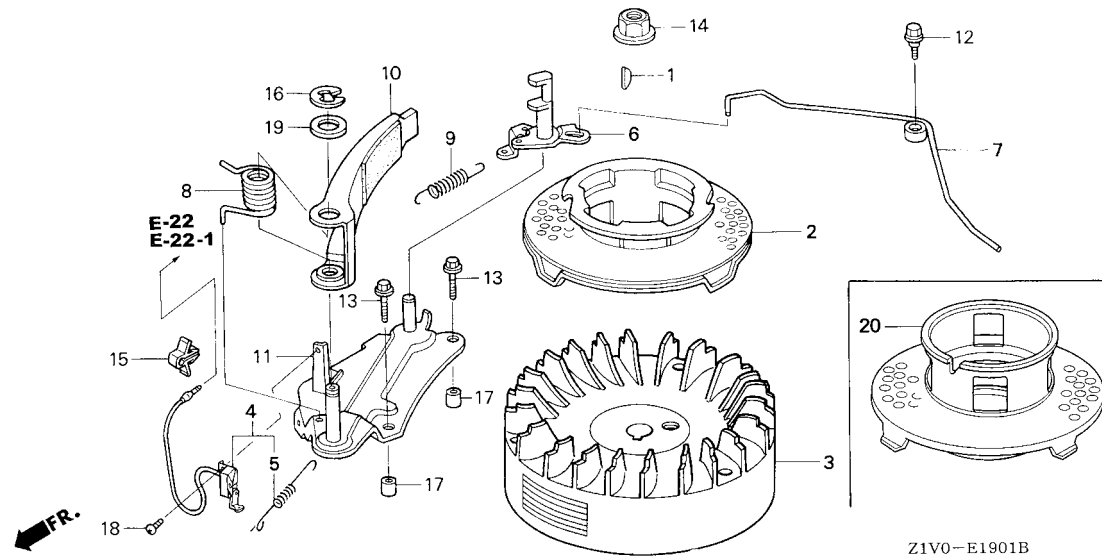

Ref. No.	L.O.N.	(Relative ref. Number) Description	F.R.T.
2		(20)	
	1121A9	PULLEY, RECOIL STARTER	0.2
	3 2161B5	FLYWHEEL	0.3
	4 6151D9	SWITCH, ENGINE STOP	0.3
	6 2161G3	CAM, FLYWHEEL BRAKE	0.4
	8 2161G2	SPRING, FLYWHEEL BRAKE	0.4
	9 2161G1	SPRING, FLYWHEEL BRAKE SHOE RETURN	0.4
	10 216130	SHOE, FLYWHEEL BRAKE	0.4

Ref. No.	Part No.	Description	Reqd. QTY GXV 160 H2	Serial No.	Parts catalogue code
1	13331-357-000	KEY, SPECIAL WOODRUFF, 25X18	1	-----	A14, A1N5, A1N5/A, A1S, A1SA, A1T5, C14/A
	13331-Z8B-900	1	-----	A1N5, A1N5/A, A1T5, C12, C14, C14/A, SFC
2	28450-Z1V-930	PULLEY COMP., STARTER	1	-----	A1N5/A, A1T5, C14/A
	28451-ZE7-003	1	1098141	A14, A1S, A1SA
			1	1113862	C12, C14, SFC
	28450-Z1V-700	1	1915343	C12, C14, SFC
			1	1916288	A1N5
3	31110-Z1V-810	FLYWHEEL COMP.(BRAKE)	1	-----	A14, A1S, A1SA
	31110-Z1V-811	1	-----	A1N5, A1N5/A, A1T5, C14/A
	31110-Z1V-810	1	1770423	C12, C14, SFC
	31110-Z1V-811	1	1770424	C12, C14, SFC
4	35120-Z1V-811	SWITCH ASSY., ENGINE STOP (BRAKE)	1	-----	A14, A1N5, A1N5/A, A1S, A1SA, A1T5, C12, C14, C14/A, SFC
5	35129-Z1V-811	SPRING, SWITCH CONTROL	1	-----	A14, A1N5, A1N5/A, A1S, A1SA, A1T5, C12, C14, C14/A, SFC
6	43140-Z1V-000	CAM COMP., BRAKE	1	-----	A14, A1N5, A1N5/A, A1S, A1SA, A1T5, C12, C14, C14/A, SFC
7	43145-ZE7-003	ROD, THROTTLE RETURN	1	-----	A14, A1S, A1SA
	43145-Z1V-003	1	-----	A1N5, A1N5/A, A1T5, C12, C14, C14/A, SFC
8	75112-ZE6-000	SPRING, BRAKE	1	-----	A14, A1N5, A1N5/A, A1S, A1SA, A1T5, C12, C14, C14/A, SFC
9	75113-ZE6-000	SPRING, BRAKE RETURN	1	-----	A14, A1N5, A1N5/A, A1S, A1SA, A1T5, C12, C14, C14/A, SFC
10	75120-ZE6-013	BRAKE COMP.	1	-----	A14, A1N5, A1N5/A, A1S, A1SA, A1T5, C12, C14, C14/A, SFC
11	75130-ZE7-000	BASE COMP., BRAKE	1	-----	A14, A1S, A1SA
	75130-ZE7-010	1	-----	A1N5/A, A1T5, C14/A
	75130-ZE7-000	1	2383403	A1N5, C12, C14, SFC
	75130-ZE7-010	1	2383404	A1N5, C12, C14, SFC
12	90015-ZE6-000	BOLT, FLANGE, 6MM	1	-----	A14, A1N5, A1N5/A, A1S, A1SA, A1T5, C12, C14, C14/A, SFC
13	90018-ZE1-000	BOLT, FLANGE, 6X23(CT200)	2	-----	A14, A1N5, A1N5/A, A1S, A1SA, A1T5, C12, C14, C14/A, SFC
14	90201-Z1T-000	NUT, SPECIAL, 14MM	1	-----	A14, A1N5, A1N5/A, A1S, A1SA, A1T5, C12, C14, C14/A, SFC



E-19-1

FLYWHEEL(2)

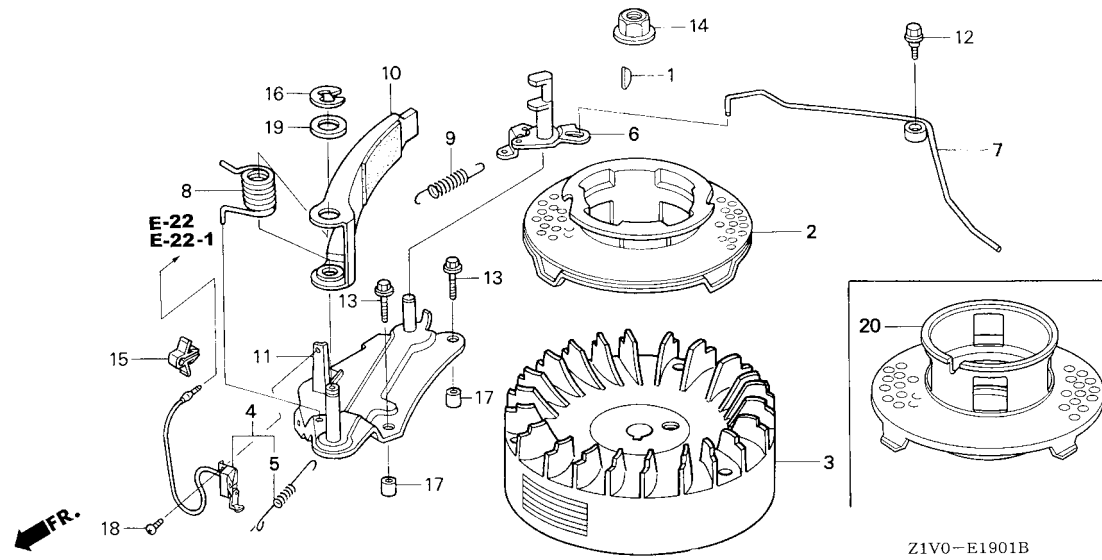

Ref. No.	Part No.	Description	Reqd. QTY		Serial No.	Parts catalogue code
			GXV	H2		
15	30701-883-000	CLIP, HIGH TENSION CORD(8MM)·	1	-----	-----	A14,A1N5,A1N5/A,A1S,A1SA,A1T5,C12,C14,C14/A,SFC
16	90653-723-000	E-RING, 10MM·	1	-----	-----	A14,A1N5,A1N5/A,A1S,A1SA,A1T5,C12,C14,C14/A,SFC
17	90702-ZE6-000	DOWEL PIN, 8X9·	2	-----	-----	A14,A1N5,A1N5/A,A1S,A1SA,A1T5,C12,C14,C14/A,SFC
18	93500-04008-0A	SCREW, PAN, 4X8·	1	-----	-----	A14,A1N5,A1N5/A,A1S,A1SA,A1T5,C12,C14,C14/A,SFC
19	94102-12800	WASHER, PLAIN, 12MM·	1	-----	-----	A14,A1N5,A1N5/A,A1S,A1SA,A1T5,C12,C14,C14/A,SFC
20	28450-Z1V-000	PULLEY COMP., STARTER·	1	-----	1916287	A1N5
			1	1098142	-----	A14,A1S,A1SA
			1	1113863	1915342	C12,C14,SFC

E-22

CONTROL(1)

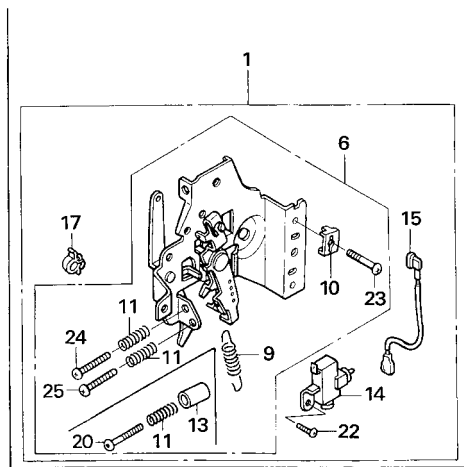
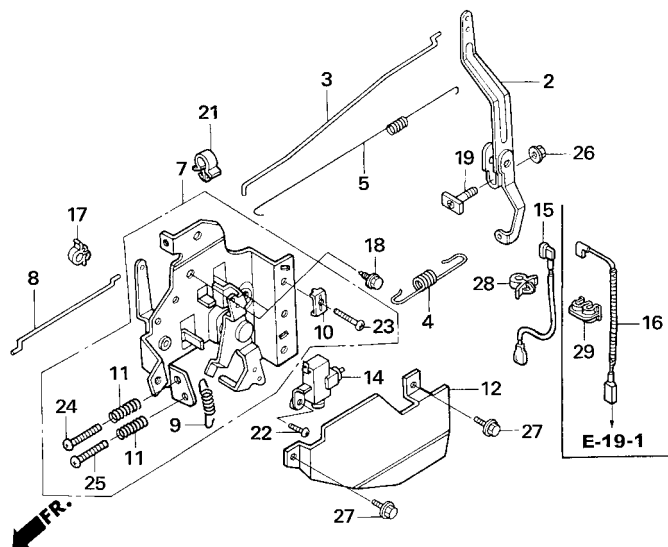

Z1V0-E2200B

Ref. No.	L.O.N.	(Relative ref. Number) Description	F.R.T.
1	(7)		
1	1161A5	CONTROL, THROTTLE/GOVERNOR ...	0.3
2	1161A0	ARM, GOVERNOR	0.3
3	1161B1	ROD, GOVERNOR	0.3
4	1161C5	SPRING, GOVERNOR	0.2
5	1161C2	SPRING, THROTTLE RETURN	0.3
8	8101R5	ROD, GOVERNOR CHOKE CONTROL ..	0.2
9	1161C0	SPRING, LEVER	0.2
14	6151G0	SWITCH, ENGINE STOP(A)	0.2
15	(16)		
	6111B3	CORD, STOP SWITCH	0.2

Ref. No.	Part No.	Description	Reqd. QTY GXV 160 H2	Serial No.	Parts catalogue code
1	16500-ZE7-W31	CONTROL ASSY.	1	-----	SFE, SFE/A, SFE1, SFE1/A, SFE4, SFE5, SFJ, SFL, SFL1, SFL5, SFN1, SFNR, SFNR/A, SFY, SFY1
2	16551-ZE7-000	ARM, GOVERNOR	1	-----	C12, N1, N4, N4C, N5, N5M, N6, N6S, N6W, N6WY, SFC, SFE, SFE/A, SFE1, SFE1/A, SFE4, SFE5, SFJ, SFL, SFL1, SFL5, SFN1, SFNR, SFNR/A, SFY, SFY1, T1AH
3	16555-ZE7-000	ROD, GOVERNOR	1	-----	C12, N1, N4, N4C, N5, N5M, N6, N6S, N6W, N6WY, SFC, SFE, SFE/A, SFE1, SFE1/A, SFE4, SFE5, SFJ, SFL, SFL1, SFL5, SFN1, SFNR, SFNR/A, SFY, SFY1, T1AH
4	16561-ZE7-020	SPRING, GOVERNOR	1	-----	C12, N1, N4, N4C, N5, N6, N6S, N6W, N6WY, SFC, SFE, SFE/A, SFE1, SFE1/A, SFE4, SFE5, SFL, SFL1, SFL5, SFN1, SFNR, SFNR/A, SFY, SFY1, T1AH
	16561-ZE7-711	1	-----	N5M, SFJ
5	16562-ZE6-000	SPRING, THROTTLE RETURN	1	-----	C12, N1, N4, N4C, N5, N5M, N6, N6S, N6W, N6WY, SFC, SFE, SFE/A, SFE1, SFE1/A, SFE4, SFE5, SFJ, SFL, SFL1, SFL5, SFN1, SFNR, SFNR/A, SFY, SFY1, T1AH
6	16570-ZE7-772	CONTROL COMP.	1	-----	N5M, N6, N6S, N6W, N6WY
	16570-ZE7-W10	1	-----	SFC, SFE, SFE/A, SFE1, SFE1/A, SFE4, SFE5, SFJ, SFL, SFL1, SFL5, SFN1, SFNR, SFNR/A, SFY, SFY1
7	16570-ZE7-020	CONTROL ASSY.	1	-----	C12, N1, N4, N4C, N5, T1AH
8	16573-ZE7-000	ROD, CHOKE	1	-----	C12, N1, N4, N4C, N5, N5M, N6, N6S, N6W, N6WY, SFC, SFE, SFE/A, SFE1, SFE1/A, SFE4, SFE5, SFJ, SFL, SFL1, SFL5, SFN1, SFNR, SFNR/A, SFY, SFY1, T1AH
9	16576-ZE7-300	SPRING, LEVER	1	-----	C12, N1, N4, N4C, N5, N5M, N6, N6S, N6W, N6WY, SFC, SFE, SFE/A, SFE1, SFE1/A, SFE4, SFE5, SFJ, SFL, SFL1, SFL5, SFN1, SFNR, SFNR/A, SFY, SFY1, T1AH
10	16576-891-000	HOLDER, CABLE	1	-----	C12, N1, N4, N4C, N5, N5M, SFC, SFE, SFE/A, SFE1, SFE1/A, SFE4, SFE5, SFJ, SFL, SFL1, SFL5, SFN1, SFNR, SFNR/A, SFY, SFY1, T1AH
	16617-VG3-000	1	-----	N6, N6S, N6W, N6WY
11	16584-883-300	SPRING, CONTROL ADJUSTING	2	-----	C12, N1, N4, N4C, N5, N5M, N6, N6S, N6W, N6WY, SFC, SFE, SFE/A, SFE1, SFE1/A, SFE4, SFE5, SFJ, SFL, SFL1, SFL5, SFN1, SFNR, SFNR/A, SFY, SFY1, T1AH
12	16585-ZE7-000	PROTECTOR, CONTROL	1	-----	C12, N1, N4, N4C, N5, N5M, N6, N6S, N6W, N6WY, SFC, SFE, SFE/A, SFE1, SFE1/A, SFE4, SFE5, SFJ, SFL, SFL1, SFL5, SFN1, SFNR, SFNR/A, SFY, SFY1, T1AH



E-22

CONTROL(1)

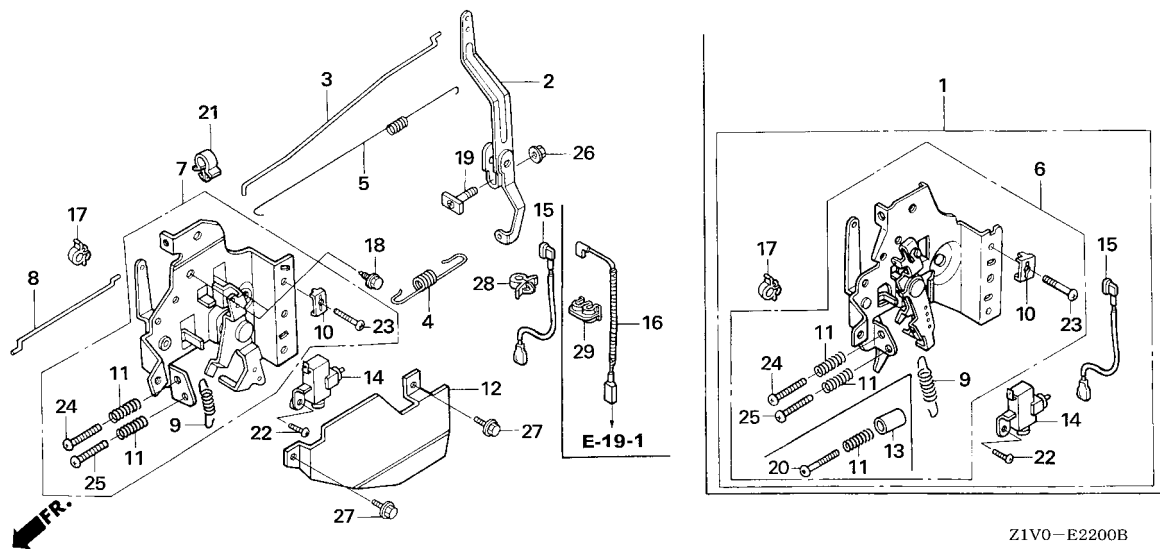

Ref. No.	Part No.	Description	Reqd. QTY		Serial No.	Parts catalogue code
			GXV	160 H2		
13	16599-ZG1-M10	COLLAR, STOPPER.....	1	-----	-----	SFC,SFE,SFE/A,SFE1,SFE1/A,SFE4,SFE5,SFJ,SFL,SFL1,SFL5,SFN1,SFNR,SFNR/A SFY,SFY1
14	36100-ZE7-013	SWITCH ASSY., ENGINE STOP....	1	-----	-----	N1,N4,N4C,N5,N5M,N6,N6S,N6W,N6WY,SFE,SFE/A,SFE1,SFE1/A,SFE4,SFE5,SFJ,SFL,SFL1,SFL5,SFN1,SFNR,SFNR/A,SFY,SFY1,T1AH
15	36101-ZE7-020	CORD, STOP SWITCH.....	1	-----	-----	N1,N4,N4C,N5M,N6,N6S,N6W,N6WY,SFE,SFE/A,SFE1,SFE1/A,SFE4,SFE5,SFJ,SFL,SFL1,SFL5,SFN1,SFNR,SFNR/A,SFY,SFY1,T1AH
	32195-Z1V-701	1	-----	1930185	N5
		1	-----	1930186	N5
16	32195-Z1V-810	CORD, STOP SWITCH(BRAKE).....	1	-----	-----	C12,SFC
17	36103-ZE1-000	HOLDER, STOP SWITCH CORD.....	1	-----	-----	N1,N4,N5M,SFE4,SFL,SFL1,SFY,SFY1,T1AH
	36103-V42-000	1	-----	-----	N4C,N5,N6,N6W,N6WY,SFE,SFE/A,SFE1,SFE1/A,SFE5,SFJ,SFL5,SFN1,SFNR,SFNR/A
18	90013-883-000	BOLT, FLANGE, 6X12(CT200)....	2	-----	-----	C12,N1,N4,N4C,N5,N5M,N6,N6S,N6W,N6WY,SFC,SFE,SFE/A,SFE1,SFE1/A,SFE4,SFE5,SFJ,SFL,SFL1,SFL5,SFN1,SFNR,SFNR/A,SFY,SFY1,T1AH
19	90015-ZE5-010	BOLT, GOVERNOR ARM.....	1	-----	-----	C12,N1,N4,N4C,N5,N5M,N6,N6S,N6W,N6WY,SFC,SFE,SFE/A,SFE1,SFE1/A,SFE4,SFE5,SFJ,SFL,SFL1,SFL5,SFN1,SFNR,SFNR/A,SFY,SFY1,T1AH
20	90016-ZE7-W00	SCREW, RECESSED, 5X28.....	1	-----	-----	SFC,SFE,SFE/A,SFE1,SFE1/A,SFE4,SFE5,SFJ,SFL,SFL1,SFL5,SFN1,SFNR,SFNR/A SFY,SFY1
21	90659-680-013	CLIP, WIRE HARNESS.....	1	-----	-----	N1,N4,N5M,SFL,SFL1,SFY,SFY1,T1AH
	90659-Z1V-003	CLIP, HARNESS.....	1	-----	-----	N6WY,SFE,SFE/A,SFE1,SFE1/A,SFE4,SFE5,SFJ,SFL5,SFN1,SFNR,SFNR/A
	90659-680-013	CLIP, WIRE HARNESS.....	1	-----	1446686	N4C,N5,N6,N6S,N6W,SFC
	90659-Z1V-003	CLIP, HARNESS.....	1	-----	1446687	N4C,N5,N6,N6S,N6W,SFC
22	93500-04008-0A	SCREW, PAN, 4X8.....	1	-----	-----	N1,N4,N4C,N5,N5M,N6,N6S,N6W,N6WY,SFE,SFE/A,SFE1,SFE1/A,SFE4,SFE5,SFJ,SFL,SFL1,SFL5,SFN1,SFNR,SFNR/A,SFY,SFY1,T1AH
23	93500-05016-0A	SCREW, PAN, 5X16.....	1	-----	-----	C12,N1,N4,N4C,N5,N5M,N6,N6S,N6W,N6WY,SFC,SFE,SFE/A,SFE1,SFE1/A,SFE4,SFE5,SFJ,SFL,SFL1,SFL5,SFN1,SFNR,SFNR/A,SFY,SFY1,T1AH
24	93500-05020-0A	SCREW, PAN, 5X20.....	1	-----	-----	C12,N1,N4,N4C,N5,N5M,N6,N6S,N6W,N6WY,SFC,SFE,SFE/A,SFE1,SFE1/A,SFE4,SFE5,SFJ,SFL,SFL1,SFL5,SFN1,SFNR,SFNR/A,SFY,SFY1,T1AH

E-22

CONTROL(1)

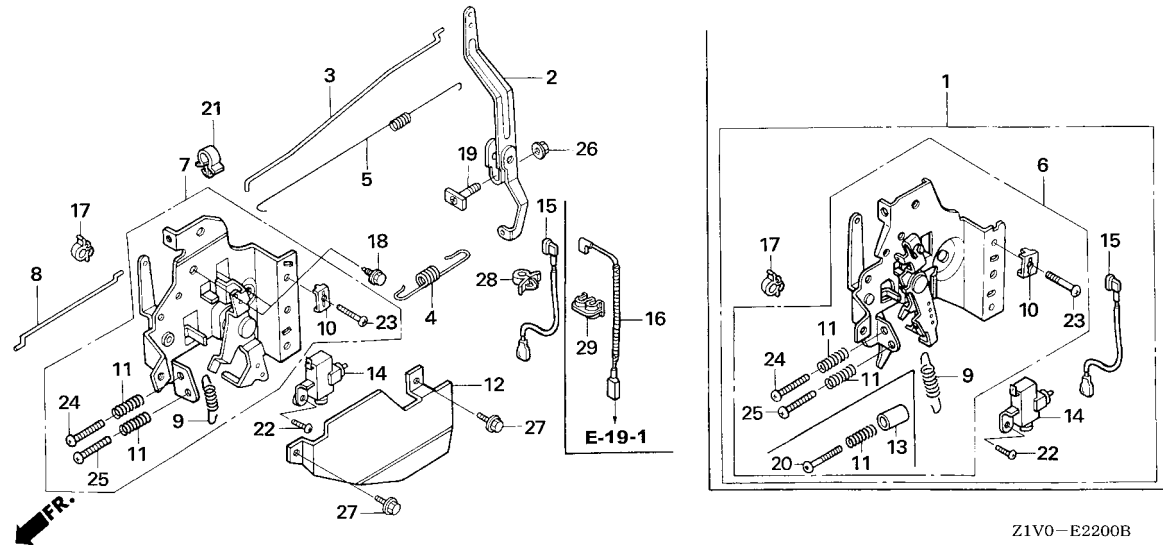

Ref. No.	Part No.	Description	Reqd. QTY		Serial No.	Parts catalogue code
			GXV 160 H2			
25	93500-05028-0A	SCREW, PAN, 5X28.....	1	-----	-----	C12,N1,N4,N4C,N5,N5M,N6,N6S,N6W,N6WY,T1AH
26	94050-06000	NUT, FLANGE, 6MM.....	1	-----	-----	C12,N1,N4,N4C,N5,N5M,N6,N6S,N6W,N6WY,SFC,SFE,SFE/A,SFE1,SFE1/A,SFE4,SFE5,SFJ,SFL,SFL1,SFL5,SFN1,SFNR,SFNR/A,SFY,SFY1,T1AH
27	95701-06010-00	BOLT, FLANGE, 6X10.....	2	-----	-----	C12,N1,N4,N4C,N5,N5M,N6,N6S,N6W,N6WY,SFC,SFE,SFE/A,SFE1,SFE1/A,SFE4,SFE5,SFJ,SFL,SFL1,SFL5,SFN1,SFNR,SFNR/A,SFY,SFY1,T1AH
28	46392-SC2-003	CLAMP, BRAKE PIPE(GRAY).....	1	-----	-----	N1,N4,N5M,SFL,SFL1,SFY,SFY1,T1AH
	46392-Z1V-003	CLAMP, HARNESS.....	1	-----	-----	N6WY,SFE,SFE/A,SFE1,SFE1/A,SFE4,SFE5,SFJ,SFL5,SFN1,SFNR,SFNR/A
	46392-SC2-003	CLAMP, BRAKE PIPE(GRAY).....	1	-----	1446521	N4C,N5,N6,N6S,N6W
	46392-Z1V-003	CLAMP, HARNESS.....	1	1446522	-----	N4C,N5,N6,N6S,N6W
29	90505-MCT-000	CLAMP, PIPE.....	1	-----	-----	C12,SFC



E-22-1

CONTROL(2)

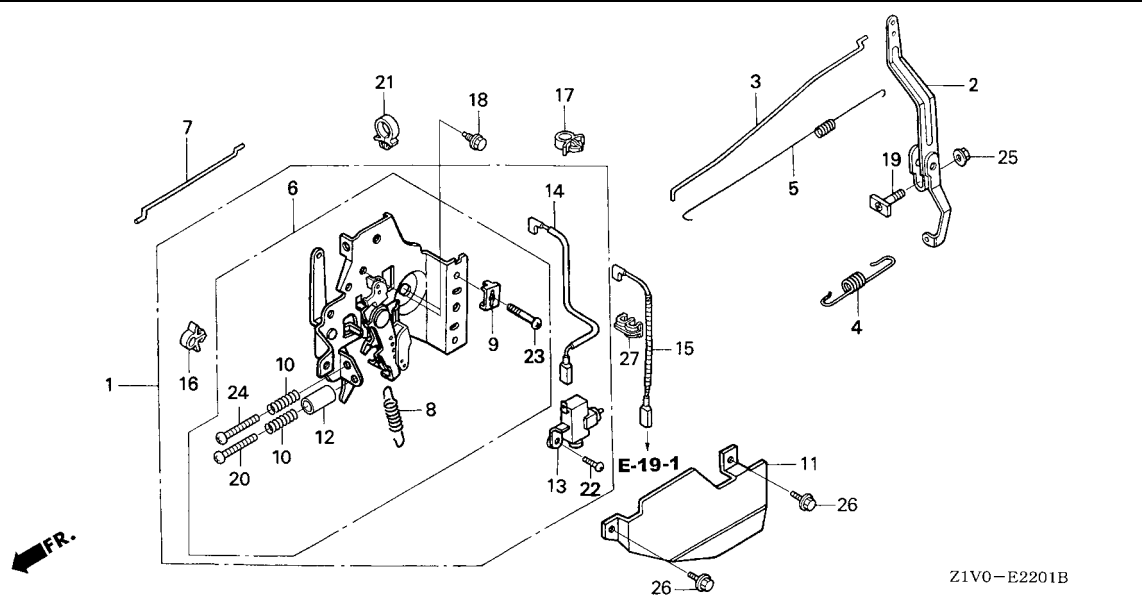

Ref. No.	L.O.N.	(Relative ref. Number) Description	F.R.T.
1	1161E1	CONTROL ASSEMBLY, THROTTLE/GOVERNOR	0.3
2	1161A0	ARM, GOVERNOR	0.3
3	1161B1	ROD, GOVERNOR	0.3
4	1161C5	SPRING, GOVERNOR	0.2
5	1161C2	SPRING, THROTTLE RETURN	0.3
6	1161D1	CONTROL, THROTTLE/GOVERNOR(A)	0.4
7	8101R5	ROD, GOVERNOR CHOKE CONTROL ..	0.2
8	1161C0	SPRING, LEVER	0.2
13	6151G0	SWITCH, ENGINE STOP(A)	0.2
14	6111B3	CORD, STOP SWITCH	0.2

Ref. No.	Part No.	Description	Reqd. QTY	Serial No.	Parts catalogue code
			GXV 160 H2		
1	16500-ZE7-W11	CONTROL ASSY.(EN)(STD.)	1	-----	N15, N155, N1B5, N1F, N1F5, N1F5/A, N45, N4N5, N4N5/A, N55
2	16551-ZE7-000	ARM, GOVERNOR	1	-----	A14, A1N5, A1N5/A, A1S, A1SA, A1T5, C14, C14/A, N15, N155, N1B5, N1F, N1F5, N1F5/A, N45, N4N5, N4N5/A, N55, T1A5
3	16555-ZE7-000	ROD, GOVERNOR	1	-----	A14, A1N5, A1N5/A, A1S, A1SA, A1T5, C14, C14/A, N15, N155, N1B5, N1F, N1F5, N1F5/A, N45, N4N5, N4N5/A, N55, T1A5
4	16561-ZE7-020	SPRING, GOVERNOR	1	-----	A14, A1N5, A1N5/A, A1S, A1SA, A1T5, C14, C14/A, N15, N155, N1B5, N1F, N1F5, N1F5/A, N45, N4N5, N4N5/A, N55, T1A5
5	16562-ZE6-000	SPRING, THROTTLE RETURN	1	-----	A14, A1N5, A1N5/A, A1S, A1SA, A1T5, C14, C14/A, N15, N155, N1B5, N1F, N1F5, N1F5/A, N45, N4N5, N4N5/A, N55, T1A5
6	16570-ZE7-W00	CONTROL COMP.(STD.)	1	-----	A14, A1N5, A1N5/A, A1T5, C14, C14/A, N15, N155, N1B5, N1F, N1F5, N1F5/A, N45, N4N5, N4N5/A, N55, T1A5
	16570-ZE7-W20	CONTROL COMP.(EN)(BRILL)	1	-----	A1S, A1SA
7	16573-ZE7-000	ROD, CHOKE	1	-----	A14, A1N5, A1N5/A, A1S, A1SA, A1T5, C14, C14/A, N15, N155, N1B5, N1F, N1F5, N1F5/A, N45, N4N5, N4N5/A, N55, T1A5
8	16576-ZE7-300	SPRING, LEVER	1	-----	A14, A1N5, A1N5/A, A1S, A1SA, A1T5, C14, C14/A, N15, N155, N1B5, N1F, N1F5, N1F5/A, N45, N4N5, N4N5/A, N55, T1A5
9	16576-891-000	HOLDER, CABLE	1	-----	A14, A1N5, A1N5/A, A1S, A1SA, A1T5, C14, C14/A, N15, N155, N1B5, N1F, N1F5, N1F5/A, N45, N4N5, N4N5/A, N55, T1A5
10	16584-883-300	SPRING, CONTROL ADJUSTING	2	-----	A14, A1N5, A1N5/A, A1S, A1SA, A1T5, C14, C14/A, N15, N155, N1B5, N1F, N1F5, N1F5/A, N45, N4N5, N4N5/A, N55, T1A5
11	16585-ZE7-000	PROTECTOR, CONTROL	1	-----	A14, A1S, A1SA, A1T5, C14/A, N15, N155, N1B5, N1F, N1F5, N1F5/A, N45, N4N5, N4N5/A, N55, T1A5
			1	1203638	C14
12	16599-ZG1-M10	COLLAR, STOPPER	1	-----	A14, A1N5, A1N5/A, A1S, A1SA, A1T5, C14, C14/A, N15, N155, N1B5, N1F, N1F5, N1F5/A, N45, N4N5, N4N5/A, N55, T1A5
13	36100-ZE7-013	SWITCH ASSY., ENGINE STOP	1	-----	N15, N155, N1B5, N1F, N1F5, N1F5/A, N45, N4N5, N4N5/A, N55, T1A5
14	36101-ZE7-020	CORD, STOP SWITCH	1	-----	N15, N155, N1B5, N1F, N1F5, N1F5/A, N45, N4N5, N4N5/A, N55, T1A5

E-22-1

CONTROL(2)

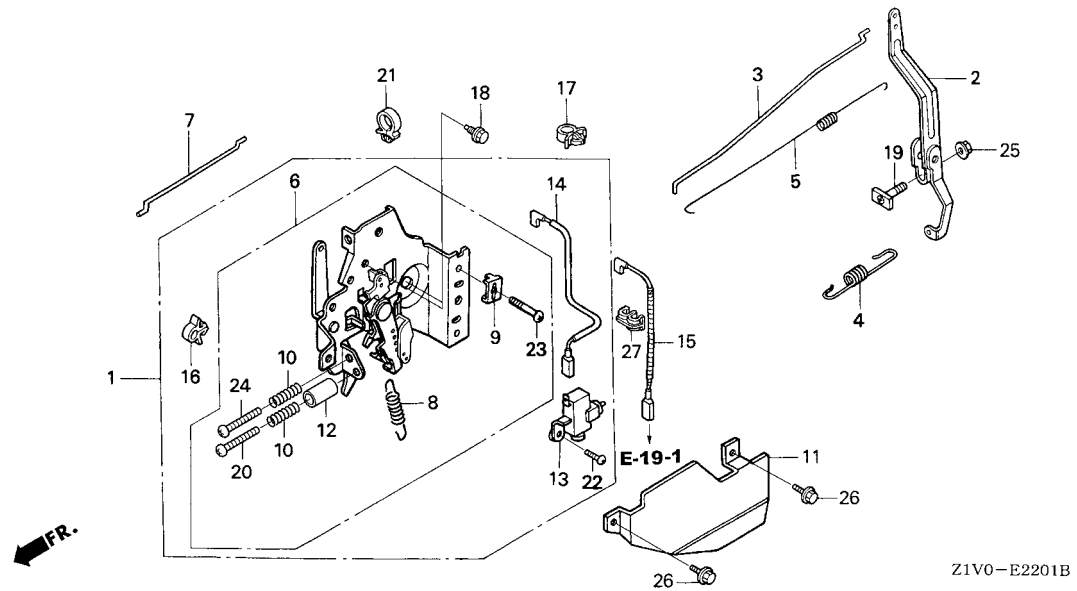

Ref. No.	Part No.	Description	Reqd. QTY		Serial No.	Parts catalogue code
			GXV 160 H2			
15	32195-Z1V-810	CORD, STOP SWITCH(BRAKE).....	1	-----	-----	A14,A1N5,A1N5/A,A1S,A1SA,A1T5,C14,C14/A
16	36103-ZE1-000 36103-V42-000	HOLDER, STOP SWITCH CORD.....	1	-----	-----	N15,N1F,N45,N55 N155,N1B5,N1F5,N1F5/A,N4N5,N4N5/A,T1A5
17	46392-SC2-003	CLAMP, BRAKE PIPE(GRAY).....	1	-----	-----	N15,N1F,N45,N55
	46392-Z1V-003	CLAMP, HARNESS.....	1	-----	-----	N155,N1B5,N1F5,N1F5/A,N4N5,N4N5/A,T1A5
18	90013-883-000	BOLT, FLANGE, 6X12(CT200).....	2	-----	-----	A14,A1N5,A1N5/A,A1S,A1SA,A1T5,C14,C14/A,N15,N155,N1B5,N1F,N1F5,N1F5/A,N45 N4N5,N4N5/A,N55,T1A5
19	90015-ZE5-010	BOLT, GOVERNOR ARM.....	1	-----	-----	A14,A1N5,A1N5/A,A1S,A1SA,A1T5,C14,C14/A,N15,N155,N1B5,N1F,N1F5,N1F5/A,N45 N4N5,N4N5/A,N55,T1A5
20	90016-ZE7-W00	SCREW, RECESSED, 5X28.....	1	-----	-----	A14,A1N5,A1N5/A,A1S,A1SA,A1T5,C14,C14/A,N15,N155,N1B5,N1F,N1F5,N1F5/A,N45 N4N5,N4N5/A,N55,T1A5
21	90659-680-013	CLIP, WIRE HARNESS.....	1	-----	-----	A14,A1S,A1SA,N15,N1F,N45,N55
	90659-Z1V-003	CLIP, HARNESS.....	1	-----	-----	A1N5,A1N5/A,A1T5,C14/A,N155,N1B5,N1F5,N1F5/A,N4N5,N4N5/A,T1A5
	90659-680-013	CLIP, WIRE HARNESS.....	1	-----	1446686	C14
	90659-Z1V-003	CLIP, HARNESS.....	1	1446687	-----	C14
22	93500-04008-0A	SCREW, PAN, 4X8.....	1	-----	-----	N15,N155,N1B5,N1F,N1F5,N1F5/A,N45,N4N5,N4N5/A,N55,T1A5
23	93500-05016-0A	SCREW, PAN, 5X16.....	1	-----	-----	A14,A1N5,A1N5/A,A1S,A1SA,A1T5,C14,C14/A,N15,N155,N1B5,N1F,N1F5,N1F5/A,N45 N4N5,N4N5/A,N55,T1A5
24	93500-05020-0A	SCREW, PAN, 5X20.....	1	-----	-----	A14,A1N5,A1N5/A,A1S,A1SA,A1T5,C14,C14/A,N15,N155,N1B5,N1F,N1F5,N1F5/A,N45 N4N5,N4N5/A,N55,T1A5
25	94050-06000	NUT, FLANGE, 6MM.....	1	-----	-----	A14,A1N5,A1N5/A,A1S,A1SA,A1T5,C14,C14/A,N15,N155,N1B5,N1F,N1F5,N1F5/A,N45 N4N5,N4N5/A,N55,T1A5
26	95701-06010-00	BOLT, FLANGE, 6X10.....	2	-----	-----	A14,A1S,A1SA,A1T5,C14/A,N15,N155,N1B5,N1F,N1F5,N1F5/A,N45,N4N5,N4N5/A,N55 T1A5
			2	1203638	-----	C14
27	90505-MCT-000	CLAMP, PIPE.....	1	-----	-----	A14,A1N5,A1N5/A,A1S,A1SA,A1T5,C14,C14/A



E-22-2

CONTROL(3)

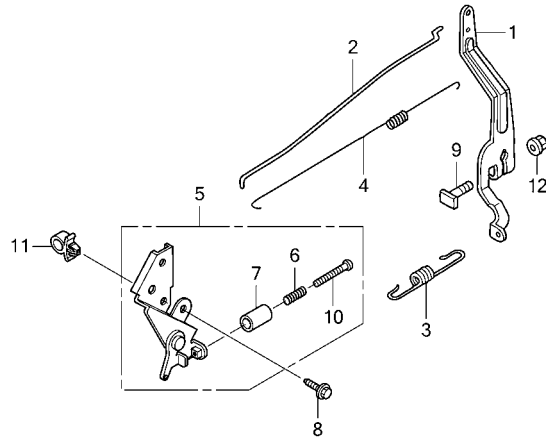

FR.

Z1V0E2202

Ref. No.	L.O.N.	(Relative ref. Number) Description	F.R.T.
1	1161A0	ARM, GOVERNOR	0.3
2	1161B1	ROD, GOVERNOR	0.3
3	1161C5	SPRING, GOVERNOR	0.2
4	1161C2	SPRING, THROTTLE RETURN	0.3
5	1161A5	CONTROL, THROTTLE/GOVERNOR ...	0.3

Ref. No.	Part No.	Description	Reqd. QTY	Serial No.	Parts catalogue code
			GXV 160 H2		
1	16551-ZE7-000	ARM, GOVERNOR	1	-----	TBE5
2	16555-ZE7-000	ROD, GOVERNOR	1	-----	TBE5
3	16561-ZE7-020	SPRING, GOVERNOR	1	-----	TBE5
4	16562-ZE6-000	SPRING, THROTTLE RETURN	1	-----	TBE5
5	16570-Z4P-800	CONTROL COMP.	1	-----	TBE5
6	16584-883-300	SPRING, CONTROL ADJUSTING	1	-----	TBE5
7	16599-ZG1-M10	COLLAR, STOPPER	1	-----	TBE5
8	90013-883-000	BOLT, FLANGE, 6X12(CT200)	2	-----	TBE5
9	90015-ZE5-010	BOLT, GOVERNOR ARM	1	-----	TBE5
10	90016-ZG1-M10	SCREW, RECESSED, 5X35	1	-----	TBE5
11	90659-Z1V-003	CLIP, HARNESS	1	-----	TBE5
12	94050-06000	NUT, FLANGE, 6MM	1	-----	TBE5

E-28

LABEL/TOOL(1)

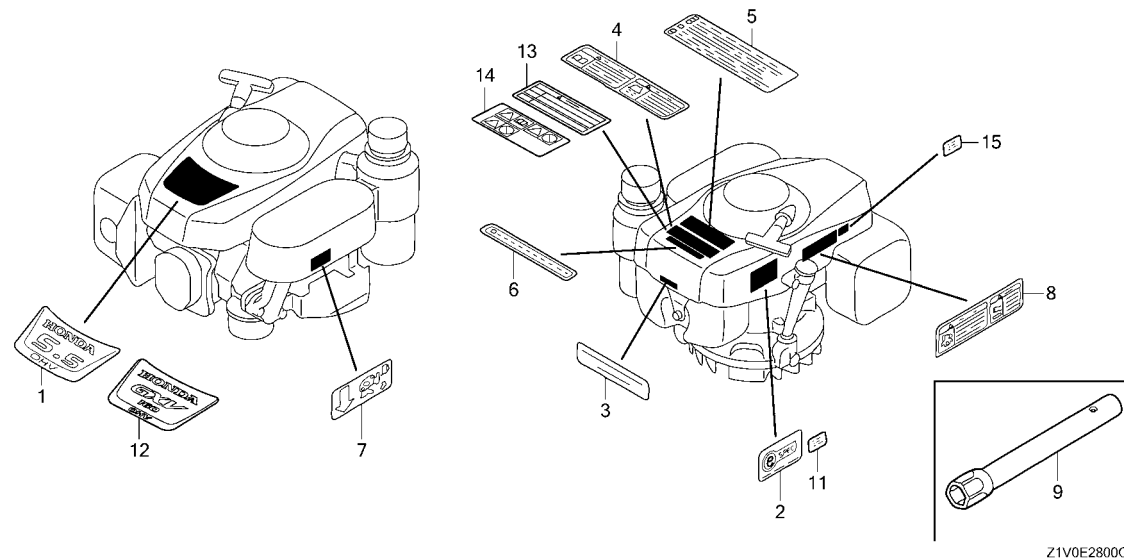

Ref. No. L.O.N. (Relative ref. Number) Description F.R.T.

NO INFORMATION

Ref. No.	Part No.	Description	Reqd. QTY GXV 160 H2	Serial No.	Parts catalogue code
1	87101-Z1V-000	MARK, EMBLEM(GXV160 5.5).....	1	-----	A14, A1S, A1SA, N1, N15, N1F, N4, N45, N55, N5M, N6S, SFL, SFL1, SFY, SFY1, T1AH
2	87135-ZE2-020	LABEL, E-SPEC(15.5X27.5).....	1	1250645	C12, C14, N4C, N5, N6, SFC
3	87504-Z1V-000	MARK, MANUFACTURER.....	1	1170174	A14, N1F, N6S, SFL, SFL1, SFY1 C12, C14, N1, N4, N5, N6, SFC, T1AH
4	87520-Z1V-000	MARK A, COMBINATION(JAPANESE)	1	-----	A14, A1N5, A1N5/A, A1S, A1SA, C12, C14, C14/A, N1, N15, N155, N1B5, N1F, N1F5, N1F5/A, N4, N45, N4C, N4N5, N4N5/A, N5, N55, N5M, N6, N6S, N6W, N6WY, SFC, SFE, SFE/A, SFE1, SFE1/A, SFE4, SFE5, SFJ, SFL, SFL1, SFL5, SFN1, SFNR, SFNR/A, SFY, SFY1, T1AH
5	87522-Z1V-000	LABEL, CAUTION.....	1	1000080	N6S, N6WY, SFJ, SFN1, SFNR, SFNR/A SFL, SFL1, SFY1
			1	1000081	A14, A1S, A1SA, C12, C14, N1, N15, N1F, N4, N45, N5, N55, N5M, N6, SFC, SFY, T1AH
			1	1192411	SFL, SFL1, SFY1 N4C
6	87522-Z1V-800	LABEL, CAUTION(CHINESE).....	1	-----	C12, C14, N4, SFC
			1	1192411	N4C
7	87524-Z1V-000	MARK, FUEL COCK CAUTION.....	1	-----	A14, A1N5, A1N5/A, A1S, A1SA, C12, C14, C14/A, N1, N15, N155, N1B5, N1F, N1F5, N1F5/A, N4, N45, N4C, N4N5, N4N5/A, N5, N55, N5M, N6, N6S, N6W, N6WY, SFC, SFE, SFE/A, SFE1, SFE1/A, SFE4, SFE5, SFJ, SFL, SFL1, SFL5, SFN1, SFNR, SFNR/A, SFY, SFY1, T1AH
8	87526-Z1V-000	MARK B, COMBINATION(JAPANESE)	1	-----	N6S, N6WY, SFJ, SFN1, SFNR, SFNR/A
			1	1000080	SFL, SFL1, SFY1
9	99004-21003	WRENCH, BOX(P21).....	1	-----	C12, C14, C14/A, N1, N15, N155, N4, N45, N4C, N4N5, N4N5/A, N5, N55, N5M, N6, N6W, N6WY, T1AH
	99004-21002	1	-----	SFC, SFE, SFE/A, SFE1, SFE1/A, SFE4, SFE5, SFJ, SFL1, SFL5, SFN1, SFNR, SFNR/A, SFY, SFY1
11	87114-ZH7-840	LABEL, WARNING (NOT CERTIFIED FOR SALE)	1	-----	A1N5, A1N5/A, N1F5, N1F5/A, N4N5, N4N5/A, SFE, SFE/A, SFE1, SFE1/A, SFE4
	87114-ZH7-000	1	-----	N4C, N6W, SFJ
			1	1075235	C12, C14, N5, N6S, SFC
			1	1149398	N6



E-28

LABEL/TOOL(1)

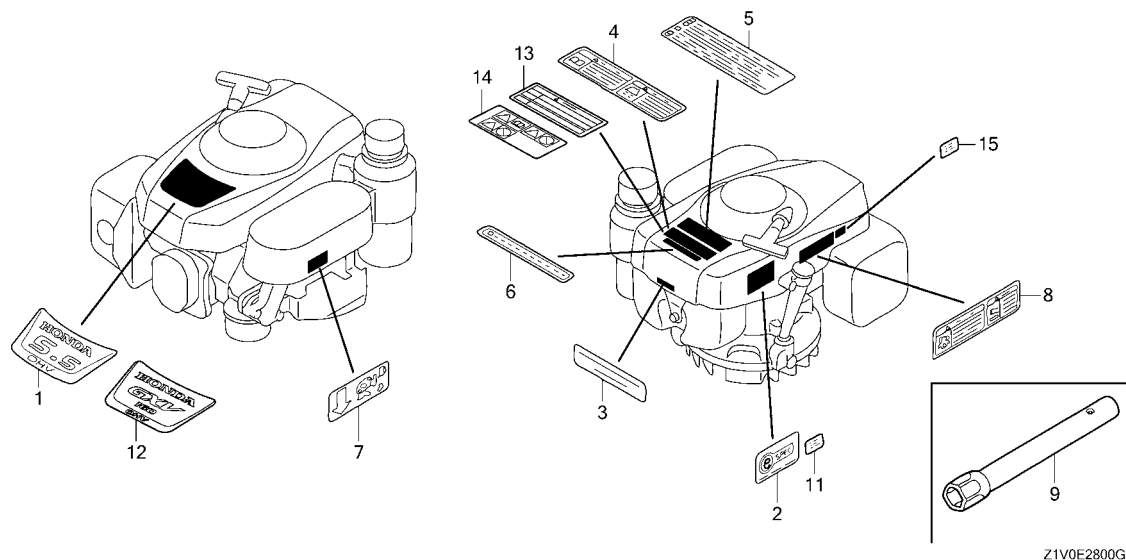

Z1V0E2800G

Ref. No.	Part No.	Description	Reqd. QTY		Serial No.	Parts catalogue code
			GXV160	H2		
12	87101-Z1V-020	MARK, EMBLEM(GXV160).....	1	-----	-----	A1N5, A1N5/A, C14/A, N155, N1B5, N1F5, N1F5/A, N4N5, N4N5/A, N6W, N6WY, SFE, SFE/A, SFE1, SFE1/A, SFE4, SFE5, SFJ, SFL5, SFN1, SFNR, SFNR/A
	87101-Z1V-010	1	1240646	-----	C12, C14, N4C, N5, N6, SFC
13	87516-ZK6-810	MARK, OPERATOR CAUTION (CHINESE)(MADE IN CHINA)	1	-----	-----	C12, C14, C14/A, N4C, SFC, SFE1/A
	87516-Z1V-800	MARK, OPERATOR CAUTION.....	1	-----	-----	N6W
14	87519-Z4N-000	MARK, OPERATOR CAUTION (PICTOGRAPH)	1	-----	-----	A1N5, A1N5/A, N155, N1B5, N1F5, N1F5/A, N4N5, N4N5/A, SFE, SFE/A, SFE1, SFE1/A, SFE4, SFE5, SFL5
15	87114-ZH7-000	LABEL, WARNING (NOT CERTIFIED FOR SALE)	1	-----	-----	C14/A, N155, N1B5, N6WY, SFE5, SFL5, SFN1, SFNR, SFNR/A



E-28-1

LABEL/TOOL(2)

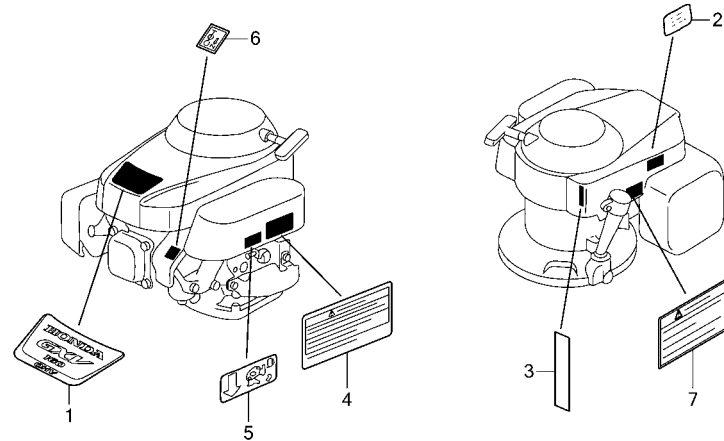

Z1V0E2801

Ref. No.	L.O.N.	(Relative ref. Number) Description	F.R.T.
----------	--------	---------------------------------------	--------

NO INFORMATION

Ref. No.	Part No.	Description	Reqd. QTY GXV 160 H2	Serial No.	Parts catalogue code
1	87101-Z1V-020	MARK, EMBLEM(GXV160).....	1	-----	A1T5,T1A5,TBE5
2	87114-ZH7-000	LABEL, WARNING (NOT CERTIFIED FOR SALE)	1	-----	A1T5,T1A5,TBE5
3	87504-Z1V-000	MARK, MANUFACTURER.....	1	-----	A1T5,T1A5,TBE5
4	87516-Z4N-010	MARK, OPERATOR CAUTION (ENGLISH)	1	-----	A1T5,T1A5,TBE5
5	87524-Z1V-000	MARK, FUEL COCK CAUTION.....	1	-----	A1T5,T1A5,TBE5
6	87528-ZL8-000	MARK, CHOKE.....	1	-----	TBE5
7	87539-Z0J-000	MARK, EX. CAUTION(ENGLISH)...	1	-----	A1T5,T1A5,TBE5



E-40

BLADE HOLDER

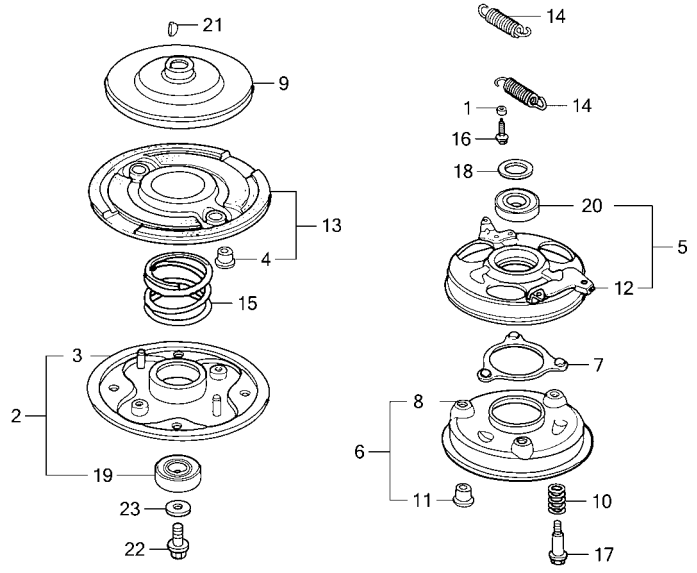

←FR.

Ref. L.O.N. (Relative ref. Number) F.R.T.
No. Description

NO INFORMATION

Ref. No.	Part No.	Description	Reqd. QTY	Serial No.	Parts catalogue code
			GXV 160 H2		
1	19512-883-000	COLLAR, FAN.....	2	-----	1134367 SFL1,SFY1
2	72600-VA4-010	HOLDER ASSY., BLADE.....	1	-----	1134367 SFL1,SFY1
3	72610-VA4-000	HOLDER COMP., BLADE.....	1	-----	1134367 SFL1,SFY1
4	72613-VA4-000	BUSH, BLADE HOLDER.....	2	-----	1134367 SFL1,SFY1
5	75090-VA4-030	PLATE ASSY., BALL CONTROL....	1	-----	1134367 SFL1,SFY1
6	75100-VA4-010	BRAKE COMP.....	1	-----	1134367 SFL1,SFY1
7	75110-VA4-000	RETAINER COMP., BALL.....	1	-----	1134367 SFL1,SFY1
8	75120-VA4-010	DISK, BRAKE.....	1	-----	1134367 SFL1,SFY1
9	75130-VA4-000	DISK, DRIVE.....	1	-----	1134367 SFL1,SFY1
10	75132-VA4-000	SPRING, BRAKE HOLDER.....	3	-----	1134367 SFL1,SFY1
11	75133-VA4-000	BUSH, BRAKE HOLDER.....	3	-----	1134367 SFL1,SFY1
12	75140-VA4-020	PLATE COMP., BALL CONTROL....	1	-----	1134367 SFL1,SFY1
13	75150-VA3-J01	DISK COMP., DRIVEN.....	1	-----	1134367 SFL1,SFY1
14	75182-VA3-J00	SPRING, CLUTCH RETURN(53.0MM)	2	-----	1134367 SFL1,SFY1
15	75183-VA3-J00	SPRING, CLUTCH(36.6MM).....	1	-----	1134367 SFL1,SFY1
16	90014-952-000	BOLT, FLANGE, 6X14(CT200)....	4	-----	1134367 SFL1,SFY1
17	90021-VA4-000	BOLT, SPECIAL, 6MM.....	3	-----	1134367 SFL1,SFY1
18	90501-952-010	WASHER, THRUST.....	1	-----	1134367 SFL1,SFY1
19	91102-VA4-013	BEARING, RADIAL BALL, 6204...	1	-----	1134367 SFL1,SFY1
20	91103-VA4-003	BEARING, RADIAL BALL, 60/22...	1	-----	1134367 SFL1,SFY1
21	94401-16150	KEY, WOODRUFF, 16X15.....	1	-----	1134367 SFL1,SFY1
22	90105-960-003	BOLT, HEX., 10X25.....	1	-----	1134367 SFL1,SFY1
23	90409-952-000	WASHER, 10MM.....	1	-----	1134367 SFL1,SFY1

2

E-40-1

OTHER PARTS

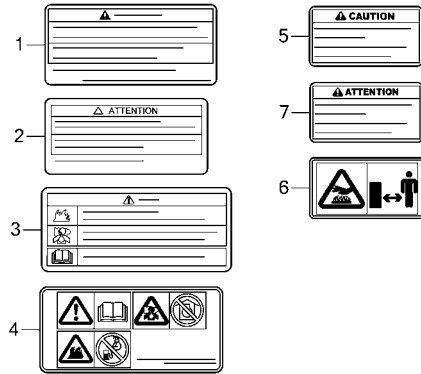

Z1V0E4001

Ref. (Relative ref. Number)
No. L.O.N. Description F.R.T.

NO INFORMATION

Ref. No.	Part No.	Description	Reqd. QTY	Serial No.	Parts catalogue code
1	87516-Z4N-010	MARK, OPERATOR CAUTION (ENGLISH)	1	-----	N155,N1B5,SFL5
2	87516-Z4N-801	MARK, OPERATOR CAUTION(FRENCH)	1	-----	A1T5,N155,N1B5,SFL5,T1A5,TBE5
3	87516-ZK6-810	MARK, OPERATOR CAUTION (CHINESE)(MADE IN CHINA)	1	-----	A1T5,T1A5,TBE5
4	87519-Z4N-000	MARK, OPERATOR CAUTION (PICTOGRAPH)	1	-----	A1T5,T1A5,TBE5
5	87539-Z0J-000	MARK, EX. CAUTION(ENGLISH) ...	1	-----	N155,N1B5,SFL5
6	87539-Z0J-800	MARK, EX. CAUTION(PICTOGRAPH)	1	-----	A1T5,T1A5,TBE5
7	87539-Z0J-810	MARK, EX. CAUTION(FRENCH) ...	1	-----	A1T5,N155,N1B5,SFL5,T1A5,TBE5



PART NO. INDEX

Part Number	Page	Ref.	Part Number	Page	Ref.	Part Number	Page	Ref.	Part Number	Page	Ref.	Part Number	Page	Ref.	
06000			13010-ZL0-004	25	1	13200-Z1V-610	28	4	16028-ZE0-005	44	7	16576-ZE7-300	55	9	
06180-ZE6-820	48	1	13011-Z1T-701	26	1	13310-Z4P-800	29	16	16045-Z1V-G01	44	8	16584-883-300	58	8	
06280-Z1V-305	36	21	13011-Z1V-931	25	1	13310-ZE7-010	28	5	16045-Z1V-WA1	44	8		55	11	
				26	1	13310-ZE7-641	28	6	16045-ZE7-005	44	8		58	10	
				27	1	13310-ZE7-661	28	7	16100-Z1V-003	44	9		60	6	
11000			13011-Z1V-932	26	1	13310-ZE7-681	28	8	16100-Z1V-801	44	9	16585-ZE7-000	55	12	
11300-Z1V-406	22	1		27	1	13310-ZE7-771	28	9	16100-Z1V-802	44	9		58	11	
11300-Z1V-407	22	2	13011-Z4K-004	25	1	13310-ZE7-U41	28	14	16100-Z1V-821	44	9	16598-Z1V-G00	47	15	
11300-Z1V-408	22	1		27	1	13310-ZE7-V10	29	17	16100-Z1V-831	44	9	16599-ZG1-M10	56	13	
11300-Z1V-409	22	1	13011-Z4P-003	25	1	13310-ZE7-V20	28	13	16100-Z1V-371	44	9		58	12	
11381-Z1V-701	22	3		27	1	13310-ZE7-V21	29	18	16100-Z4P-WC1	44	9		60	7	
11381-ZE7-M10	22	3	13011-ZL0-003	25	1	13331-357-000	52	1	16124-ZE0-005	44	10	16611-Z1V-G00	47	16	
				26	1		53	1	16141-Z0S-003	45	23	16617-VG3-000	55	10	
			13011-ZL0-004	25	1	13331-Z8B-900	52	1	16166-Z1V-003	44	11	16617-Z4P-000	24	54	
				26	1		53	1		45	11	16854-ZH8-000	49	1	
12000			13012-Z1T-701	25	1				16166-Z1V-801	44	11		51	23	
12000-Z1V-000	22	4	13012-Z1V-931	26	1	14000				45	11	16910-ZE8-015	51	25	
12000-Z1V-405	22	4		27	1				16166-Z1V-J71	45	11	16952-Z1V-000	49	2	
12000-Z1V-406	22	4	13012-Z1V-932	26	1	14100-ZE7-000	30	2	16166-Z4P-WA1	45	11	16953-ZDK-003	45	16	
12000-Z1V-407	22	4		27	1	14100-ZE7-770	30	2	16211-ZE7-000	45	12	16953-ZE1-812	45	16	
12000-Z2J-000	22	4	13012-Z4K-004	25	1	14100-ZE7-N40	30	2	16212-Z1V-701	45	13	16954-ZE1-812	45	17	
12000-Z2J-405	22	4		27	1	14410-ZE1-010	30	3	16212-ZE7-M10	45	13	16956-ZE1-811	45	18	
12000-ZE7-405	22	4	13012-Z4P-003	25	1	14431-Z1T-000	30	4	16220-ZE6-010	45	14	16957-ZE1-812	45	19	
12000-ZE7-406	22	4		27	1	14431-ZE1-000	30	4	16221-Z1V-701	45	15				
12125-Z1V-000	22	5	13012-ZL0-003	25	1	14441-ZE1-010	30	5	16221-ZE7-M11	45	15	17000			
12125-Z1V-G00	22	5		26	1	14451-Z7E-000	30	6	16500-ZE7-W11	58	1				
12126-Z1V-000	23	49	13012-ZL0-004	25	1	14451-ZE1-013	30	6	16500-ZE7-W31	55	1	17210-Z1V-003	46	2	
12126-Z1V-800	23	49		26	1	14568-ZE1-000	30	7	16510-ZE6-000	23	13	17210-Z1V-601	47	13	
12200-ZE7-405	20	3	13013-Z1T-701	25	1	14711-ZF1-000	30	8	16511-ZE1-000	23	14	17218-888-003	46	3	
12204-ZE1-306	20	1	13013-Z1V-931	26	1	14721-ZE7-000	30	9	16512-ZE6-000	23	15	17220-Z1V-000	46	4	
12205-ZE1-315	20	2		27	1	14751-ZE1-000	30	10	16513-ZE1-000	23	16	17220-Z1V-010	46	4	
12209-ZE6-003	30	1	13013-Z1V-932	26	1	14771-Z1T-000	30	11	16515-ZE6-010	23	17	17220-Z1V-601	46	4	
12216-ZE5-300	20	4		27	1	14771-ZE1-000	30	11	16525-ZE6-010	23	18	17220-Z1V-602	46	4	
12251-Z1V-003	20	5	13013-Z4K-004	25	1	14791-ZE1-010	30	12	16531-Z1T-000	23	19	17224-Z4P-800	42	1	
12251-Z1V-701	20	5		27	1				16541-ZE7-000	23	20	17231-Z1V-000	46	5	
12251-ZE7-000	20	5	13013-Z4P-003	25	1	15000			16551-ZE7-000	55	2	17231-Z1V-601	46	5	
12310-Z1V-S40	20	6		27	1					58	2	17231-Z1V-601	47	12	
12311-ZG9-800	20	6	13013-ZL0-003	25	1	15335-ZE7-000	22	10		60	1	17232-891-000	47	6	
12312-Z1V-701	20	7		26	1	15620-ZE6-810	23	11	16555-ZE7-000	55	3	17232-Z1V-601	47	14	
12355-Z1V-000	22	6	13013-ZL0-004	25	1	15630-ZE6-810	23	12		58	3	17238-Z1V-601	47	7	
12367-883-003	22	7		26	1	15721-ZE7-000	46	1		60	2	17238-ZE7-710	47	7	
12372-ZE7-000	22	8	13101-Z1T-000	27	2				16561-ZE7-020	55	4	17239-Z1V-601	47	8	
12373-ZE7-000	22	9	13101-Z1T-010	27	2	16000				58	4	17239-ZE6-300	47	8	
12391-ZE7-M10	20	7	13101-ZDK-013	27	2	16010-Z1T-721	43	1		60	3	17240-ZE6-000	23	21	
				27	2	16010-Z4P-WA1	43	1	16561-ZE7-711	55	4	17506-ZE7-000	49	3	
				27	2	16010-ZE0-025	43	1	16562-ZE6-000	55	5	17510-Z1V-010	49	4	
13000			13102-ZDK-003	27	2	16011-ZE0-005	43	2		58	5	17510-Z4P-810	49	4	
13010-Z1T-701	25	1	13102-ZE7-020	27	2	16013-Z0S-B01	43	3	16570-Z4P-800	60	4	17512-Z4P-811	49	5	
13010-Z1V-931	26	1	13102-ZH8-020	27	2	16013-ZE0-005	43	3	16570-ZE7-020	55	7	17512-ZE7-000	49	5	
			13103-ZDK-003	27	2	16015-Z1T-WA1	43	4	16570-ZE7-772	55	6	17516-896-700	49	6	
13010-Z1V-932	26	1	13103-ZE7-020	27	2	16015-Z4P-WA1	43	4	16570-ZE7-W00	58	6	17518-Z1V-000	49	7	
			13103-ZH8-020	27	2	16015-ZE0-831	43	4	16570-ZE7-W10	55	6	17519-Z1V-000	49	8	
13010-Z4K-004	25	1	13104-ZDK-003	27	2	16016-ZDF-V01	43	5	16570-ZE7-W20	58	6	17532-Z1V-000	49	9	
			13104-ZE7-020	27	2	16016-ZH7-W01	43	5	16573-ZE7-000	55	8	17560-Z1V-000	24	50	
			13104-ZH8-020	27	2	16024-Z1T-WA1	43	6		58	7	17560-Z1V-G00	24	55	
13010-Z4P-003	25	1		28	2	16024-ZE1-811	43	6	16576-891-000	24	52	17620-Z0J-800	51	27	
			13111-Z1T-000	28	3	16024-ZH7-A20	43	6		55	10	17620-Z1V-000	50	10	
13010-ZL0-003	25	1	13200-Z1V-000	28	4	16028-Z1T-WA1	44	7		58	9	17622-888-010	50	11	
			13200-Z1V-600	28	4								28410-Z1V-003ZA	34	2

PART NO. INDEX

Part Number	Page	Ref.	Part Number	Page	Ref.	Part Number	Page	Ref.	Part Number	Page	Ref.	Part Number	Page	Ref.
28410-Z1V-003ZB	34	2	30500-Z1V-003	40	2	72610-VA4-000	64	3	90000			90581-Z1V-000	40	4
28410-Z1V-701ZA	34	2	30500-Z1V-013	40	2	72613-VA4-000	64	4					42	10
	37	2	30500-Z1V-701	41	6				90001-Z1T-000	28	10	90601-ZE1-000	23	33
28410-Z1V-701ZB	34	2	30700-Z1V-003	40	5	75000			90001-ZE1-000	28	10	90602-ZE1-000	23	34
	37	2	30700-Z1V-601	40	5				90003-ZH8-801	36	13	90653-723-000	54	16
28410-ZE7-003ZB	32	2		41	5	75090-VA4-030	64	5				90659-680-013	56	21
28410-ZE7-003ZD	32	2		42	5	75100-VA4-010	64	6	90010-GE0-710	50	15		59	21
28420-Z1V-003	35	3	30700-Z1V-701	40	5	75110-VA4-000	64	7	90010-Z1V-800	50	15	90659-Z1V-003	56	21
28420-Z1V-702	37	3	30701-883-000	54	15	75112-ZE6-000	53	8	90012-ZE0-010	30	13		59	21
28420-ZE7-003	32	3				75113-ZE6-000	53	9	90013-883-000	20	8		60	11
28422-896-010	32	4	31000			75120-VA4-010	64	8				90681-959-003	42	11
28422-Z1T-701	36	16				75120-ZE6-013	53	10				90701-ZE6-000	23	35
	38	4	31110-Z1V-003	52	4	75130-VA4-000	64	9				90702-ZE6-000	54	17
28422-ZH8-801	35	4	31110-Z1V-810	52	5	75130-ZE7-000	53	11	90014-952-000	20	8	90741-ZV4-000	28	15
28431-896-000	32	5		53	3	75130-ZE7-010	53	11						
28431-ZH8-801	35	5	31110-Z1V-811	52	5	75132-VA4-000	64	10				91000		
	38	5		53	3	75133-VA4-000	64	11						
28433-Z1T-702	38	6				75140-VA4-020	64	12				91102-VA4-013	64	19
28433-ZH8-801	35	6	32000			75150-VA3-J01	64	13				91103-VA4-003	64	20
28441-896-000	32	6				75182-VA3-J00	64	14				91205-Z1V-003	23	36
28441-ZH8-801	35	7	32195-Z1V-701	56	15	75183-VA3-J00	64	15	90014-Z1V-000	50	16	91231-Z1V-003	23	37
	38	7	32195-Z1V-810	56	16				90015-883-000	40	3	91251-Z1V-003	23	38
28442-896-700	32	7		59	15	80000						91252-Z1V-003	23	39
28442-ZH8-003	35	8	32763-PA0-000	42	6				90015-ZE5-010	56	19	91301-Z1V-003	23	40
	38	8				80103-MG2-000	50	14				91302-Z1V-003	23	41
28443-896-000	32	8	35000									91424-ZBC-801	51	26
28443-Z1T-701	36	19				87000			90015-ZE6-000	53	12			
	38	9	35120-Z1V-811	53	4				90016-Z1V-000	50	17	92000		
28443-ZH8-801	35	9	35129-Z1V-811	53	5	87101-Z1V-000	61	1	90016-ZE7-W00	56	20			
28450-Z1V-000	52	7				87101-Z1V-010	62	12				92101-06012-0H	32	11
	54	20	36000			87101-Z1V-020	62	12	90016-ZG1-M10	60	10			
28450-Z1V-700	52	3							90017-883-000	23	27	93000		
	53	2	36100-ZE7-013	56	14	87114-ZH7-000	61	11	90018-ZE1-000	53	13			
28450-Z1V-930	52	3		58	13				90021-VA4-000	64	17	93500-03006-1H	45	20
	53	2	36101-Z4P-800	42	7				90022-888-010	23	28	93500-04008-0A	54	18
28451-ZE7-003	52	3	36101-ZE7-020	56	15	87114-ZH7-840	61	11	90029-888-000	42	9		56	22
	53	2		58	14	87135-ZE2-020	61	2	90043-Z1V-000	21	9		59	22
28461-ZE1-003	33	14	36103-V42-000	56	17	87504-Z1V-000	61	3	90043-ZE6-000	21	9	93500-05016-0A	23	42
	35	10		59	16				90048-Z1V-000	21	10		56	23
28461-ZE1-013	35	10	36103-ZE1-000	56	17	87516-Z1V-800	62	13	90048-ZC3-000	21	10		59	23
	38	10		59	16	87516-Z4N-010	63	4	90105-960-003	64	22	93500-05020-0A	56	24
28461-ZE7-T00	32	9							90131-ZE1-000	23	29		59	24
28461-ZH8-003	35	11	43000			87516-Z4N-801	65	2	90201-Z1T-000	52	6	93500-05028-0A	57	25
28461-ZH8-013	35	11				87516-ZK6-810	62	13						
	38	10	43140-Z1V-000	53	6				90201-Z1V-601	47	9	94000		
28462-Z1T-701	35	12	43143-Z1V-000	23	25	87519-Z4N-000	62	14	90206-ZE1-000	30	14			
	39	11	43145-Z1V-003	53	7				90300-Z1V-000	47	9	94050-06000	47	10
28462-Z1V-801	35	12	43145-ZE7-003	53	7	87520-Z1V-000	61	4	90343-ZE6-000	48	8		51	19
28462-Z1V-811	35	12				87522-Z1V-000	61	5	90401-ZE7-W00	28	11		57	26
	39	11	46000			87522-Z1V-800	61	6	90409-952-000	64	23		59	25
28462-Z1V-831	39	11				87524-Z1V-000	61	7	90451-Z1T-000	23	30		60	12
28462-ZA7-003	32	10	46392-SC2-003	57	28				90451-ZE1-000	23	30	94101-06800	23	43
28462-ZE7-V11	32	10		59	17	87526-Z1V-000	61	8	90452-166-600	23	31	94102-12800	54	19
28462-ZH8-003	35	12	46392-Z1V-003	57	28	87528-ZL8-000	63	6	90452-187-000	23	32	94103-06000	42	12
				59	17	87539-Z0J-000	63	7	90455-896-700	51	18		51	20
30000									90501-952-010	64	18	94251-08000	23	44
			72000			87539-Z0J-800	65	6	90505-MCT-000	57	29	94301-08140	23	45
30100-Z1V-601	40	2				87539-Z0J-810	65	7				94301-10160	21	11
	42	4	72600-VA4-010	64	2				90551-ZE1-000	28	12	94401-16150	64	21



PART NAME INDEX

Part name	Page	Ref.	Part name	Page	Ref.	Part name	Page	Ref.
[A]			BRAKE COMP.	53	10	CONTROL ASSY.	55	1
ARM, GOVERNOR	55	2	BUSH, BLADE HOLDER	64	6			7
	58	2	BUSH, BRAKE HOLDER	64	4	CONTROL COMP.	58	1
	60	1		64	11		55	6
ARM, VALVE ROCKER	30	4	[C]				58	6
ARRESTER KIT, SPARK	48	1	CAMSHAFT ASSY.	30	2	CORD, STOP SWITCH	60	5
ARRESTER, SPARK	48	5	CAM COMP., BRAKE	53	6		42	7
[B]			CAP ASSY., FUEL TANK	50	10		56	15
BARREL ASSY., CYLINDER	22	4		51	27			16
BASE COMP., BRAKE	53	11	CAP ASSY., NOISE SUPPRESSOR ..	40	5	COVER COMP., BREATHER	22	6
BASE COMP., HOLDER	23	25		41	5	COVER COMP., FAN	40	1
BEARING, RADIAL BALL, 60/22 ...	64	20		42	5		42	3
BEARING, RADIAL BALL, 6204 ...	64	19	CARBURETOR ASSY.	44	9	COVER COMP., HEAD	20	6
BEARING, RADIAL BALL, 6205 ...	23	48	CASE COMP., AIR CLEANER	46	4	COVER, AIR CLEANER	46	5
BOLT, CONNECTING ROD	28	10	CASE COMP., RECOIL STARTER ...	32	2		47	12
BOLT, DRAIN PLUG	23	29		34	2	COVER, HEAD	20	6
BOLT, FLANGE, 6MM	53	12	CHAMBER SET, FLOAT	37	2	CRANKSHAFT COMP.	28	5
BOLT, FLANGE, 6X10	57	27	CHOKE SET	43	4			6
	59	26	CLAMP, BRAKE PIPE	44	8			7
BOLT, FLANGE, 6X12	20	8		57	28			8
	23	46	CLAMP, CORD	59	17			9
	24	51	CLAMP, HARNESS	42	6			13
	42	13		57	28			14
	56	18	CLAMP, PIPE	59	17		29	16
	59	18	CLAMP, TUBE	57	29			17
BOLT, FLANGE, 6X14	60	8		59	27	CUSHION, RR. FENDER	50	14
	20	8	CLAMP, TUBE	51	28			
	21	8		29	29	[D]		
	23	14	CLIP A, CABLE	42	11	DISK COMP., DRIVEN	64	13
	24	26	CLIP, GOVERNOR HOLDER	23	34	DISK, BRAKE	64	8
	24	53	CLIP, HARNESS	56	21	DISK, DRIVE	64	9
	64	16		59	21	DOWEL PIN, 10X16	21	11
BOLT, FLANGE, 6X16	42	9	CLIP, HIGH TENSION CORD	60	11	DOWEL PIN, 8X14	23	45
BOLT, FLANGE, 6X20	23	28	CLIP, PISTON PIN, 18MM	54	15	DOWEL PIN, 8X9	54	17
BOLT, FLANGE, 6X23	53	13	CLIP, TUBE	28	12			
BOLT, FLANGE, 6X28	40	3		50	15	[E]		
	42	8		51	21	ELEMENT, AIR CLEANER	46	2
BOLT, FLANGE, 6X32	23	27	CLIP, VALVE GUIDE	20	4		47	13
BOLT, FLANGE, 6X35	47	11	CLIP, WIRE HARNESS	56	21	E-RING, 10MM	54	16
BOLT, FLANGE, 6X47	50	16		59	21	EXTENSION, OIL FILLER	23	12
BOLT, FLANGE, 6X8	33	12	COIL ASSY., IGNITION	40	2	[F]		
	36	14		41	6	FAN, COOLING	52	2
BOLT, FLANGE, 8X50	39	13	COIL ASSY., IGNITION & CAP			FILTER, BREATHER	22	7
	21	12	ASSY., NOISE SUPPRESSOR	40	2	FILTER, OUTER	46	3
	23	47		42	4	FLOAT SET	43	3
BOLT, GOVERNOR ARM	56	19	COLLAR B, AIR CLEANER	47	8	FLYWHEEL COMP.	52	4
	59	19	COLLAR COMP., TANK	49	8			5
	60	9	COLLAR, AIR CLEANER	47	7			3
BOLT, HEX., 10X25	64	22	COLLAR, EXTENSION	23	21			5
BOLT, HEX., 6X12	32	11	COLLAR, FAN	64	1			3
BOLT, PIVOT, 8MM	30	13	COLLAR, STOPPER	56	13			5
BOLT, SPECIAL, 6MM	64	17		58	12			3
BOLT, STUD, 6X109	21	9	COLLAR, TANK SET	60	7			
BOLT, STUD, 6X85	21	10		49	7	[G]		
BOLT, STUD, 6X97	21	9				GASKET SET	43	1
BOLT, TANK STAY	50	17						

PART NAME INDEX

Part name	Page	Ref.	Part name	Page	Ref.	Part name	Page	Ref.
GASKET, CYLINDER HEAD	20	5	LABEL, WARNING	61	11	PACKING, FUEL CAP	50	12
GASKET, MUFFLER	48	6		62	15	PACKING, FUEL COCK	45	19
		7		63	2	PACKING, HEAD COVER	20	7
GAUGE COMP., OIL LEVEL	23	11	LEVER, COCK	45	16	PACKING, INSULATOR	45	13
GAUGE, FUEL LEVEL	50	13	LIFTER, VALVE	30	5	PACKING, OIL PAN	22	3
GEAR, DRIVEN	23	24				PACKING, PROTECTOR	48	2
GOVERNOR ASSY.	23	13	[M]			PAN ASSY., OIL	22	1
GRIP, STARTER	32	9						2
GROMMET, AIR CLEANER	47	6	MARK A, COMBINATION	61	4	PIN, GOVERNOR WEIGHT	23	16
		14	MARK B, COMBINATION	61	8	PIN, LOCK, 2.0	23	35
GUIDE, EX. VALVE	20	2	MARK, CHOKE	63	6	PIN, LOCK, 8MM	23	44
GUIDE, IN. VALVE	20	1	MARK, EMBLEM	61	1	PIN, PISTON	28	3
GUIDE, RATCHET	35	6		62	12	PISTON	27	2
	38	6		63	1		28	2
[H]			MARK, EX. CAUTION	63	7	PIVOT, ROCKER ARM	30	6
				65	5	PLATE ASSY., BALL CONTROL	64	5
HEAD COMP., CYLINDER	20	3		6	6	PLATE A, GUIDE	23	49
HOLDER ASSY., BLADE	64	2	MARK, FUEL COCK CAUTION	61	7	PLATE COMP., BALL CONTROL	64	12
HOLDER COMP., BLADE	64	3		63	5	PLATE, FRICTION	32	5
HOLDER, CABLE	24	52	MARK, MANUFACTURER	61	3		35	5
		54		63	3		38	5
	55	10	MARK, OPERATOR CAUTION	62	13	PLATE, GOVERNOR SHAFT HOLDER ..	23	18
	58	9			14	PLATE, GUIDE	22	5
HOLDER, GOVERNOR WEIGHT	23	15		63	4	PLATE, LEVER SETTING	45	17
HOLDER, STOP SWITCH CORD	56	17		65	1	PLATE, PUSH ROD GUIDE	30	12
	59	16			2	PLUG, SPARK	21	13
					3	PROTECTOR COMP., MUFFLER	48	4
[I]					4	PROTECTOR, CONTROL	55	12
			MUFFLER COMP.	48	3		58	11
INSULATOR, CARBURETOR	45	12				PULLEY COMP., STARTER	52	3
			[N]					7
[J]							53	2
			NOZZLE, MAIN	44	11		54	20
JET SET, PILOT, #35	45	22		45	11	PULLEY, RECOIL STARTER	32	3
JET SET, PILOT, #40	45	22	NUT, AIR CLEANER	47	9			
JET, MAIN, #60	45	21	NUT, FLANGE, 6MM	47	10	[R]		
JET, MAIN, #62	45	21		51	19	RATCHET, STARTER	32	4
JET, MAIN, #65	45	21		57	26		35	4
JET, MAIN, #68	45	21		59	25		36	16
				60	12		38	4
[K]			NUT, PIVOT ADJUSTING	30	14	REEL, RECOIL STARTER	35	3
KEY, SPECIAL WOODRUFF, 25X18 ..	52	1	NUT, SELF-LOCK, 6MM	48	8		37	3
	53	1	NUT, SPECIAL, 14MM	52	6	RETAINER COMP., BALL	64	7
KEY, SPECIAL, 16X15	28	15		53	14	RETAINER, IN. VALVE SPRING	30	11
KEY, WOODRUFF, 16X15	64	21	[O]			RETAINER, VALVE SPRING	30	11
KNOB, RECOIL STARTER	33	14				RING SET, PISTON	25	1
	35	10	OIL SEAL, 12X20X6.5	23	36		26	1
		11	OIL SEAL, 25X38X7	23	38	ROD ASSY., CONNECTING	27	1
	38	10	OIL SEAL, 25.4X40X7	23	39	ROD, CHOKÉ	28	4
			OIL SEAL, 6X11X4	23	37		55	8
[L]			O-RING, 22.1X2.2	23	40	ROD, CHOKE CONTROL	58	7
			O-RING, 25.5X3	23	41	ROD, CHOKE CONTROL	47	16
LABEL, CAUTION	61	5	[P]			ROD, GOVERNOR	55	3
		6					58	3
LABEL, E-SPEC	61	2	PACKING, BREATHER COVER	22	9	ROD, PUSH	60	2
			PACKING, CARBURETOR	45	15	ROD, THROTTLE RETURN	30	3
							53	7



PART NAME INDEX

Part name	Page	Ref.	Part name	Page	Ref.	Part name	Page	Ref.
ROPE, RECOIL STARTER	32	10	SPRING, RECOIL STARTER	32	7	WASHER, THRUST, 25.6MM	28	11
	35	12		35	8	WASHER, THRUST, 6MM	23	30
	39	11		38	8	WEIGHT, GOVERNOR	23	14
RUBBER B, TANK MOUNTING	49	6	SPRING, RETURN	32	8	WRENCH, BOX	61	9
RUBBER, OIL RETURN	22	10		35	9			
RUBBER, RADIATOR MOUNTING	42	2		36	19			
RUBBER, SUPPORTER	49	1		38	9			
	51	23	SPRING, SWITCH CONTROL	53	5			
RUBBER, TANK MOUNTING	49	9	SPRING, THROTTLE RETURN	55	5			
RUBBER, TANK SETTING	49	3		58	5			
				60	4			
[S]			SPRING, VALVE	30	10			
SCREW SET	43	5	SPRING, WEIGHT RETURN	30	7			
	44	7	STARTER ASSY., RECOIL	32	1			
SCREW SET, DRAIN	43	6		33	13			
SCREW SET, PILOT	43	5		34	1			
SCREW, PAN, 3X6	45	20		36	15			
SCREW, PAN, 4X8	54	18	STARTER SET, RECOIL	37	1			
	56	22	STAY COMP., FAN COVER	36	21			
	59	22	STAY COMP., FAN COVER	24	55			
SCREW, PAN, 5X16	23	42	STAY COMP., TANK	24	50			
	56	23	STAY, CHOKÉ CONTROL	47	15			
	59	23	STAY, FUEL TUBE	42	1			
SCREW, PAN, 5X20	56	24	STRAINER COMP., FUEL	51	25			
	59	24	STRAINER, FUEL	49	2			
SCREW, PAN, 5X28	57	25	SWITCH ASSY., ENGINE STOP	53	4			
SCREW, RECESSED, 5X28	56	20		56	14			
	59	20		58	13			
SCREW, RECESSED, 5X35	60	10	[T]					
SCREW, SETTING	36	13	TANK COMP., FUEL	49	4			
	39	12	TUBE, BREATHER	46	1			
SCREW, THROTTLE STOP	44	10	TUBE, FUEL	49	5			
SEAL, VALVE STEM	30	1	TUBE, FUEL, 4.2X210	51	26			
SHAFT, DRIVE	23	23	TUBE, VINYL, 9X11X30	51	24			
SHAFT, GOVERNOR ARM	23	20	[V]					
SHAFT, GOVERNOR HOLDER	23	17	VALVE SET, FLOAT	43	2			
SLIDER, GOVERNOR	23	19	VALVE, BREATHER	22	8			
SPACER COMP., CARBURETOR	45	14	VALVE, EX.	30	9			
SPONGE, FUEL CAP BREATHER	50	11	VALVE, IN.	30	8			
SPRING, BRAKE	53	8	[W]					
SPRING, BRAKE HOLDER	64	10	WASHER, 10MM	64	23			
SPRING, BRAKE RETURN	53	9	WASHER, 10X21	23	32			
SPRING, CLUTCH	64	15	WASHER, DRAIN PLUG, 10.2MM	23	33			
SPRING, CLUTCH RETURN	64	14	WASHER, PLAIN	45	23			
SPRING, COCK LEVER	45	18	WASHER, PLAIN, 12MM	54	19			
SPRING, CONTROL ADJUSTING	55	11	WASHER, PLAIN, 6MM	23	43			
	58	10		40	4			
	60	6		42	10			
SPRING, FRICTION	32	6		51	12			
	35	7	WASHER, TANK MOUNTING	51	18			
	38	7	WASHER, THRUST	64	18			
SPRING, GOVERNOR	55	4	WASHER, THRUST, 12MM	23	31			
	58	4						
	60	3						
SPRING, LEVER	55	9						
	58	8						

1

FOREWORD INDEX

2

ENGINE GROUP

3

PART NUMBER INDEX

4

PART NAME INDEX

HONDA

HONDA PARTS CATALOGUE NEWS

PARTS CATALOGUE - CORRECTED

CODE NO.	13Z1V403
PARTS CATALOGUE NEWS	GXV160H2
NEWS NO.	001

Block No.	Ref. No.	Note	Part No.	Description	Reqd. QTY GXV 160 H2	Serial No.	Parts catalogue code
E-3	4	L	12000-Z1V-405	BARREL ASSY., CYLINDER.....	1	-----	A1N5, C14
					1	----- 3029976	C12, SFC
		T	12000-Z1V-406	1	-----	N155, N1B5, N1F5/A, N4N5/A, N6WY, SFE/A, SFE1/A, SFE5, SFL5, SFNR/A T1A5, TBE5
					1	3029977 -----	N4C, N5, N6, N6W, SFJ, SFN1
		T	12000-Z1V-407	1	-----	A1N5/A, A1T5, C14/A
					1	3029977 -----	C12, SFC
L	12000-Z2J-405	1	-----	N1F5, N4N5, N6S, SFE, SFE1, SFE4, SFNR		
			1	----- 3029976	N4C, N5, N6, N6W, SFJ, SFN1		
E-12	1	L	19610-Z1V-000ZA	COVER COMP., FAN *R280*..... POWER RED	1	-----	A14, A1S, A1SA, C14, N1, N15, N1F, N4, N45, N55, N5M, N6S, SFE, SFE1 SFE4, SFL, SFL1, SFNR, SFY, SFY1
					1	----- 3029976	C12, N4C, N5, N6, N6W, SFC, SFN1
		L	19610-Z1V-000ZB	*NH1*..... BLACK	1	-----	A14, A1N5, A1S, A1SA, N15, N1F, N1F5, N45, N4N5, N55, N5M, SFE1, SFE4 SFL1, T1AH
					1	----- 3029976	SFJ, SFN1
T	19610-Z1V-930ZA	*R280*..... POWER RED	1	-----	C14/A, N155, SFE/A, SFE1/A, SFE5, SFL5, SFNR/A		

NOTE A:PART NO. CHANGE D:NEWLY PROVIDED E:PART NO. DELETION K:REQUIRED NO. CORRECTION L:APPLICATION SERIAL NO. CORRECTION
M:PART DESCRIPTION CORRECTION T:APPLICATION CORRECTION Z:REMARKS CHANGE

PARTS CATALOGUE NEWS

BOOKNo. : 13Z1V403

Block No.	Ref. No.	Note	Part No.	Description	Reqd. QTY GXV 160 H2	Serial No.	Parts catalogue code
					1	3029977	C12, N4C, N5, N6, N6W, SFC, SFN1
		T	19610-Z1V-930ZB	*NH1*.....BLACK	1	-----	A1N5/A, N155, N1B5, N1F5/A, N4N5/A, N6WY, SFE/A, SFE1/A, SFE5, SFL5
					1	3029977	N6, N6W, SFJ, SFN1
E-19	3	L	28450-Z1V-700	PULLEY COMP., STARTER.....	1	-----	SFNR
					1	1915343	SFE, SFE1, SFE4
					1	1915343 3029976	N4C, N5, N6, N6W, SFN1
					1	1916288	N1F5, N4N5
					1	1916288 3029976	SFJ
		T	28450-Z1V-930	1	-----	N155, N1B5, N1F5/A, N4N5/A, N6WY, SFE/A, SFE1/A, SFE5, SFL5, SFNR/A T1A5, TBE5
					1	3029977	N4C, N5, N6, N6W, SFJ, SFN1
E-19-1	2	L	28450-Z1V-700	PULLEY COMP., STARTER.....	1	1915343	C14
					1	1915343 3029976	C12, SFC
					1	1916288	A1N5
		T	28450-Z1V-930	1	-----	A1N5/A, A1T5, C14/A
					1	3029977	C12, SFC
E-28	3	T	87504-Z1V-000	MARK, MANUFACTURER.....	1	-----	A14, A1S, A1SA, N1, N15, N1F, N4, N45, N55, N5M, N6S, SFE4, SFJ, SFL SFL1, SFY, SFY1, T1AH
		D	87504-Z1V-010	1	-----	A1N5, A1N5/A, C12, C14, C14/A, N155, N1B5, N1F5, N1F5/A, N4C, N4N5 N4N5/A, N5, N6, N6W, N6WY, SFC, SFE, SFE/A, SFE1, SFE1/A, SFE5, SFL5 SFN1, SFNR, SFNR/A
	13	E	87516-Z1V-800	*PART NO. DELETION			
		D	87516-Z1V-801	MARK, OPERATOR CAUTION.....	1	-----	N6W
		T	87516-Z1V-810	MARK, OPERATOR CAUTION (CHINESE) (MADE IN CHINA)	1	-----	C12, C14, N4C, SFC, SFE1/A
		D	87516-ZK6-811	1	-----	C14/A
E-28-1	3	E	87504-Z1V-000	*PART NO. DELETION			

NOTE A:PART NO. CHANGE D:NEWLY PROVIDED E:PART NO. DELETION K:REQUIRED NO. CORRECTION L:APPLICATION SERIAL NO. CORRECTION
M:PART DESCRIPTION CORRECTION T:APPLICATION CORRECTION Z:REMARKS CHANGE

PARTS CATALOGUE NEWS

BOOKNo. : 13Z1V403

Block No.	Ref. No.	Note	Part No.	Description	Reqd. QTY GXV 160 H2	Serial No.	Parts catalogue code
		D	87504-Z1V-010	MARK, MANUFACTURER.....	1	-----	A1T5, T1A5, TBE5

NOTE A:PART NO. CHANGE D:NEWLY PROVIDED E:PART NO. DELETION K:REQUIRED NO. CORRECTION L:APPLICATION SERIAL NO. CORRECTION
M:PART DESCRIPTION CORRECTION T:APPLICATION CORRECTION Z:REMARKS CHANGE

HONDA PARTS CATALOGUE NEWS

PARTS CATALOGUE - CORRECTED

CODE NO.	13Z1V403
PARTS CATALOGUE NEWS	GXV160H2
NEWS NO.	002

Block No.	Ref. No.	Note	Part No.	Description	Reqd. QTY GXV 160 H2	Serial No.	Parts catalogue code
E-28	11	L	87114-ZH7-000	LABEL, WARNING (NOT CERTIFIED FOR SALE)	1	-----	N4C, N6W, SFJ
						1075235	C12, C14, N5, N6S, SFC
		1	1149398	3016336	N6		
	15	D	87114-ZH7-850	LABEL, WARNING (NOT CERTIFIED FOR SALE)	1	3016337	N6

NOTE A:PART NO. CHANGE D:NEWLY PROVIDED E:PART NO. DELETION K:REQUIRED NO. CORRECTION L:APPLICATION SERIAL NO. CORRECTION
M:PART DESCRIPTION CORRECTION T:APPLICATION CORRECTION Z:REMARKS CHANGE