

MARLYAMA

OPERATOR'S MANUAL

LANDSCAPE BLADE ATTACHMENT

Type 4

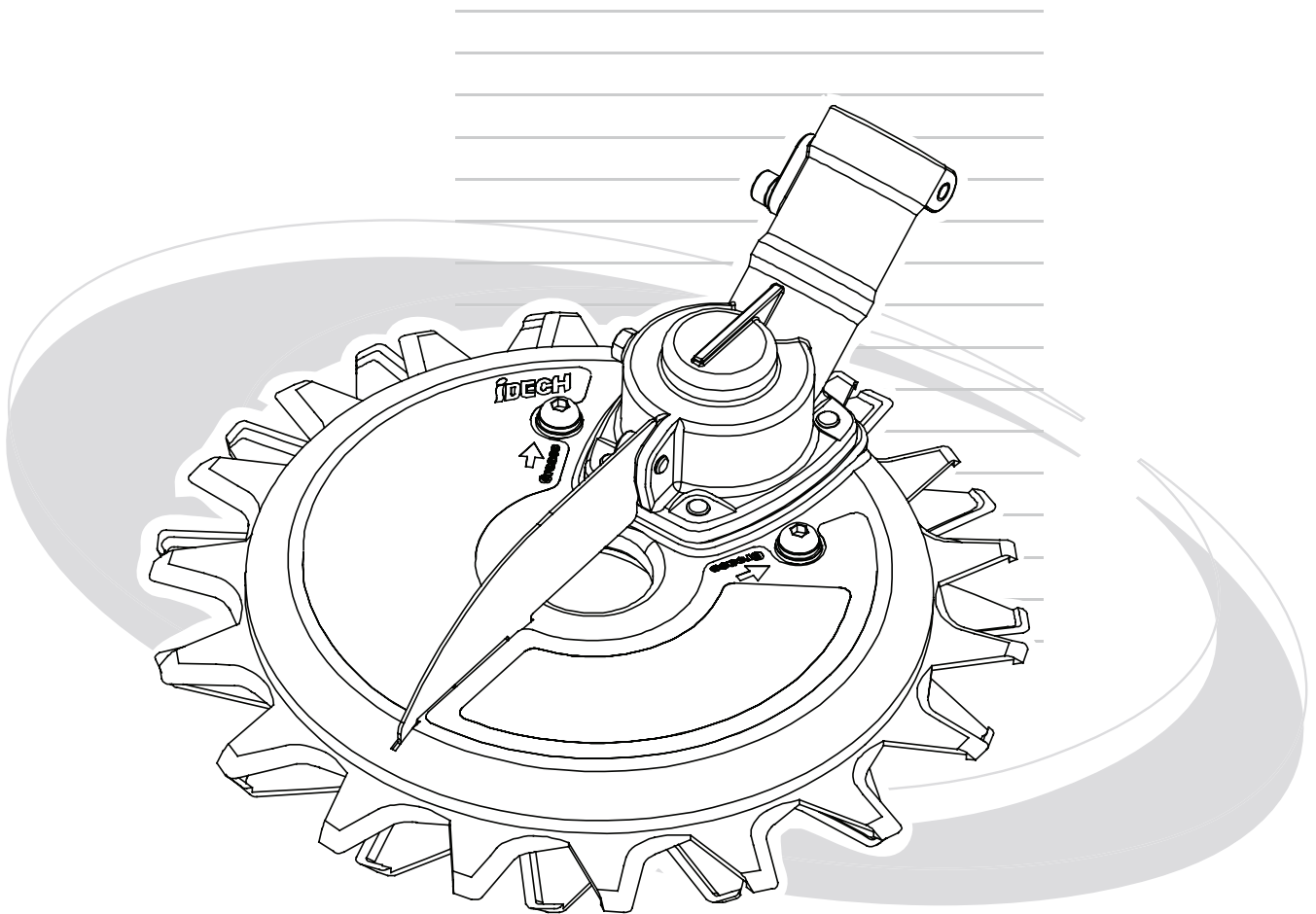

Premium Outdoor Power Equipment  **MARLYAMA** *Extraordinary.*

Completely read and understand this manual prior to using this product .

SAFETY ISSUES

Very important

Read and understand all the safety warnings in this Owner's Manual before using the Landscape Blade .



DANGER!

Be careful not to touch the blades. The blades are sharp and may cause serious injury.

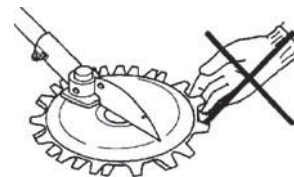

WARNING!

Wear safety glasses while using the Landscape Blade .

Wear gloves when handling the Landscape Blade .

Be very careful of the blades.

Wear protective clothing for grass cutting work.



Allow the Landscape Blade to cool sufficiently after operation, before you touch it.

The Landscape Blade heats up during operation due to the friction of the blades.

Danger!
Very Hot!



If a foreign object, such as a piece of wire becomes tangled in the Landscape Blade stopping blade rotation, stop the engine first before removing the object. If blade rotation is still not smooth after removing the object, see the "Maintenance" section of this manual (Page 8) for further troubleshooting information.

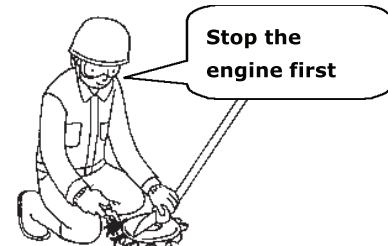

ATTENTION!

Use only for lawn and grass cutting.

To avoid malfunction or injury do not modify your **Landscape Blade** .

To avoid blade damage do not drop or hit your **Landscape Blade** .



Shield the blades with the protective cover when not in use.

The blades must be free and not touch anything while starting the brushcutter engine.



Blades off the ground for starting!

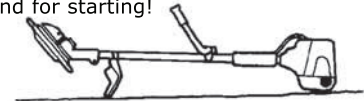

Obstacles like plastic bags and steel wires in the grass should be removed before cutting the grass to prevent them from becoming entangled in the blades.

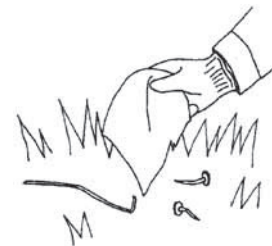

The **Landscape Blade** is water resistant. However, if it is used in a wet area, wipe the blades and lubricate after each use.

Do not completely submerge the **Landscape Blade** and the brushcutter in water.

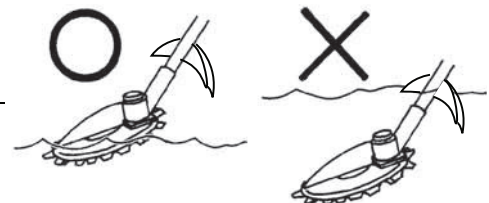

See page 8 for maintenance after use.

Sharpen the blades if grass cutting efficiency drops. See sharpening (page 13), maintenance (page 8).

Periodically lubricate the **Landscape Blade** to ensure proper performance (See page 11).

Parts list

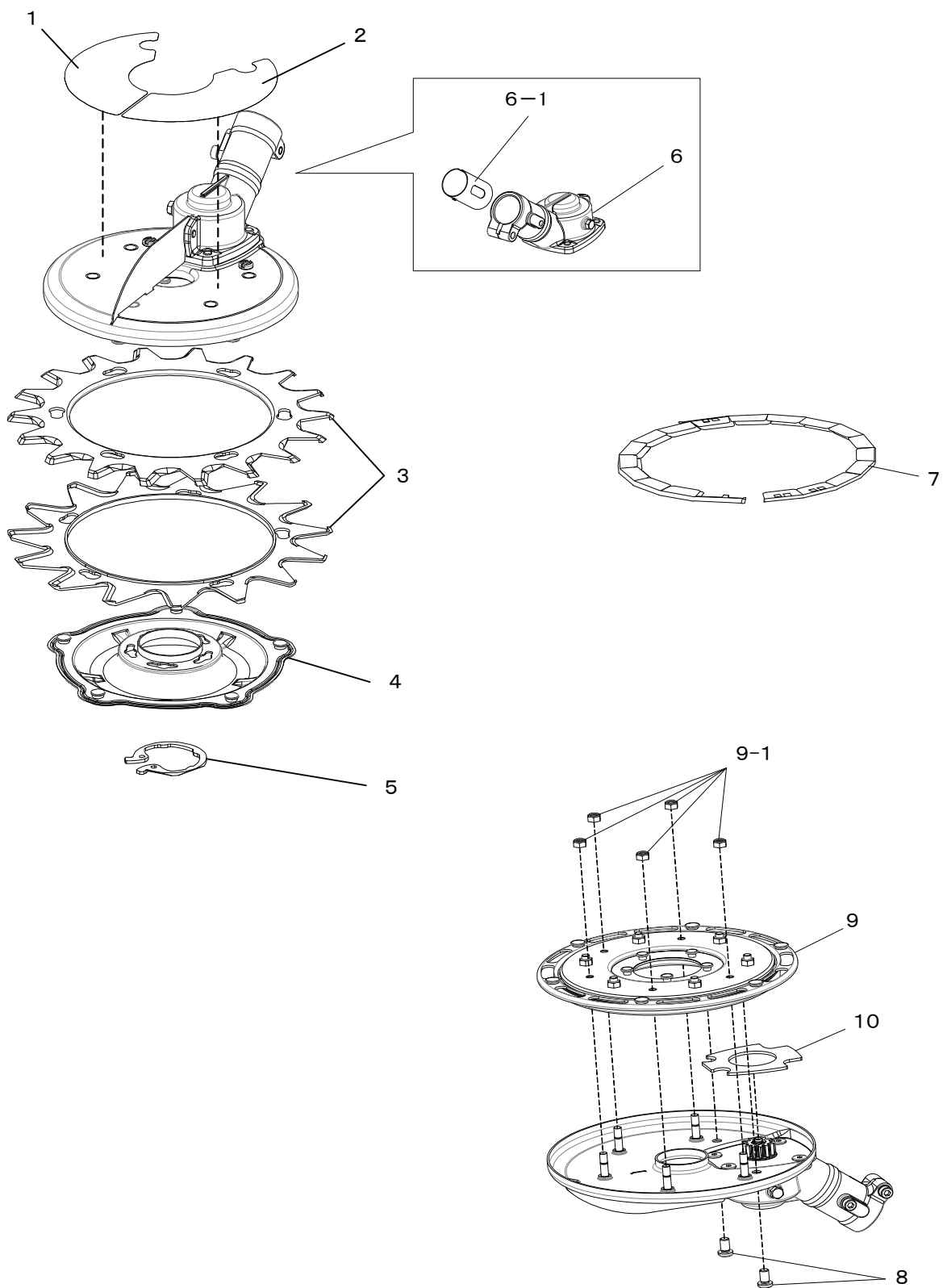

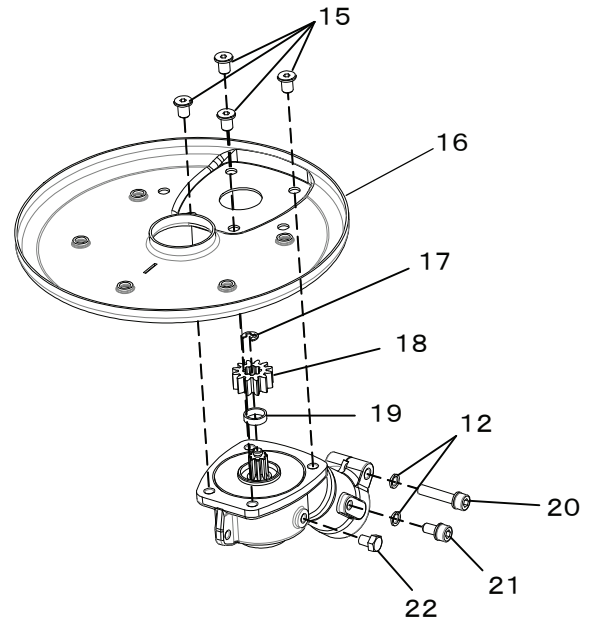
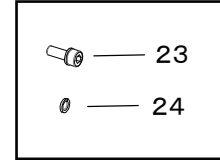
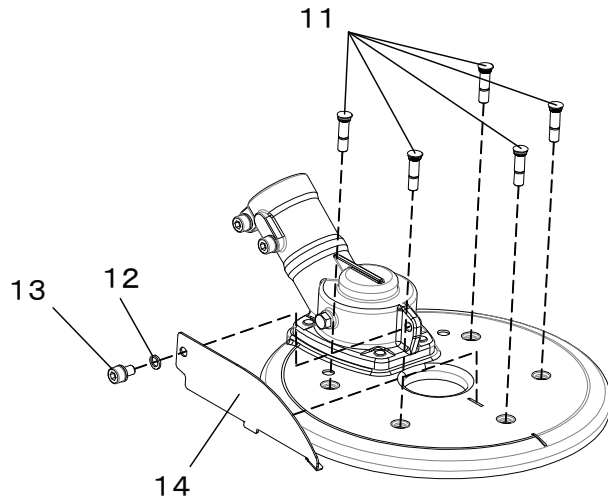

Ref No.	Part No.	Part Name	Part Quantity
1	SKR-26MS	Type Label	1
2	SKR-17MS	Caution Label	1
3	SK-1815NMS	Upper Blade 18/Lower Blade 15	1Set
4	SKNW-19	Bottom Disk	1
5	SKN-22	Bottom Disk Fixing Bracket	1
6	SKR-06	Gear Case	1
6-1	TKS-24	Sleeve ϕ 24	1
7	SKAN-21	Blade Protection Cover	1
8	SKN-12	Sems Cap Screw M6 \times 10	2
9	SKR-11	Gear Unit	1
9-1	SKR-27	U-Nut M5	11
10	SKR-08	Rubber Seal	1
11	SKR-36	Stud Screw M5 \times 18	5
12	SKAN-04	Spring Washer M5	3
13	SKAN-05	Cap Screw M5 \times 8	1
14	SKR-07	Stabilizer	1
15	SKR-10	Low Head Cap Screw M6 \times 8	4
16	SKR-09	Body Case	1
17	SKR-13	E-Ring 4	1
18	SKAN-14	Drive Pinion Gear	1
19	SKR-15	Output Shaft Spacer	1
20	SKAN-02	Cap Screw M5 \times 25	1
21	SKAN-01	Fit Screw M5 \times 12	1
22	SKAN-03	Hex Screw M5 \times 6	1
23	SKAN-01B	Screw M5 \times 12(Black)	1
24	SKAN-04B	Spring Washer M5(Black)	1

MOUNTING

To mount the Landscape Blade to your brushcutter you must remove the existing gear case.

- Loosen the clamp screw on the guard mount, and slide the guard up the tube out of the way.

WARNING

Do not remove the guard from the guard tube. They are necessary for the safe operation of the Landscape Blade.

- Take out the screw (A) locating the gear case (C) on the guard tube (D).
- Loosen the clamp screw (B) and pull the gear case (C) off the guard tube.
- Slip the Landscape Blade into place on the guard tube (D), so that the screw holes align (A).
- Insert the locating screw (A) and tighten it securely.
- Tighten the clamp screw (B) securely.
- Slide the guard down over the rear of the blades, and tighten the clamp screw securely.

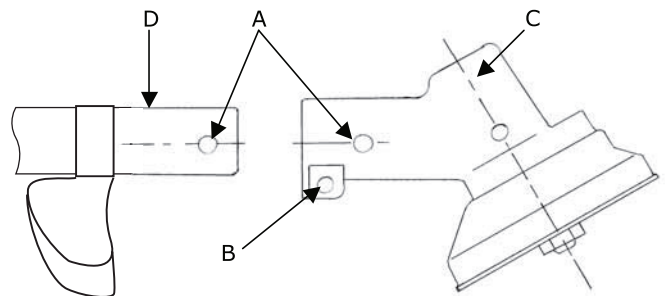

OPERATION



Adjust the shoulder strap and grip position, so that the blade face is parallel to the ground.



Just place the Landscape Blade on the ground and swing it for easy and comfortable grass cutting work.

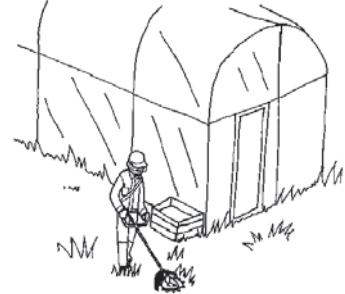

There is a minimal risk of damage to glass windows by flying debris.



The Landscape Blade ejects less dangerous flying debris than a conventional string trimmer.



Grass cutting work can be done in a place with lots of stones, or cans.



Grass in a wet area or even in shallow water can also be cut with ease.

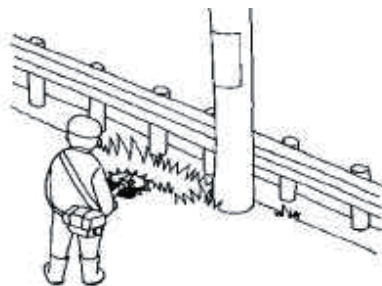

Grass on the edge of the road, or around poles can be cut with ease.



Grass close to a wall, solid fence or tree can be easily trimmed with minimal damage because of blunt edged blades and minimal back because the blades counter rotate.

This product can suppress flying stones. Although it is not necessary that without flying. Make sure the safety confirmation to the surroundings and wear safety glasses while using.

MAINTENANCE



- * Make sure the engine is stopped before replacing the blades.
- * Wear safety glass and gloves to handle the blades.

Follow the procedure as described below to remove the blades.

To remove the bottom disc fixing bracket

- * Be careful not to jump out the bottom disc fixing bracket while mounting it.

1.

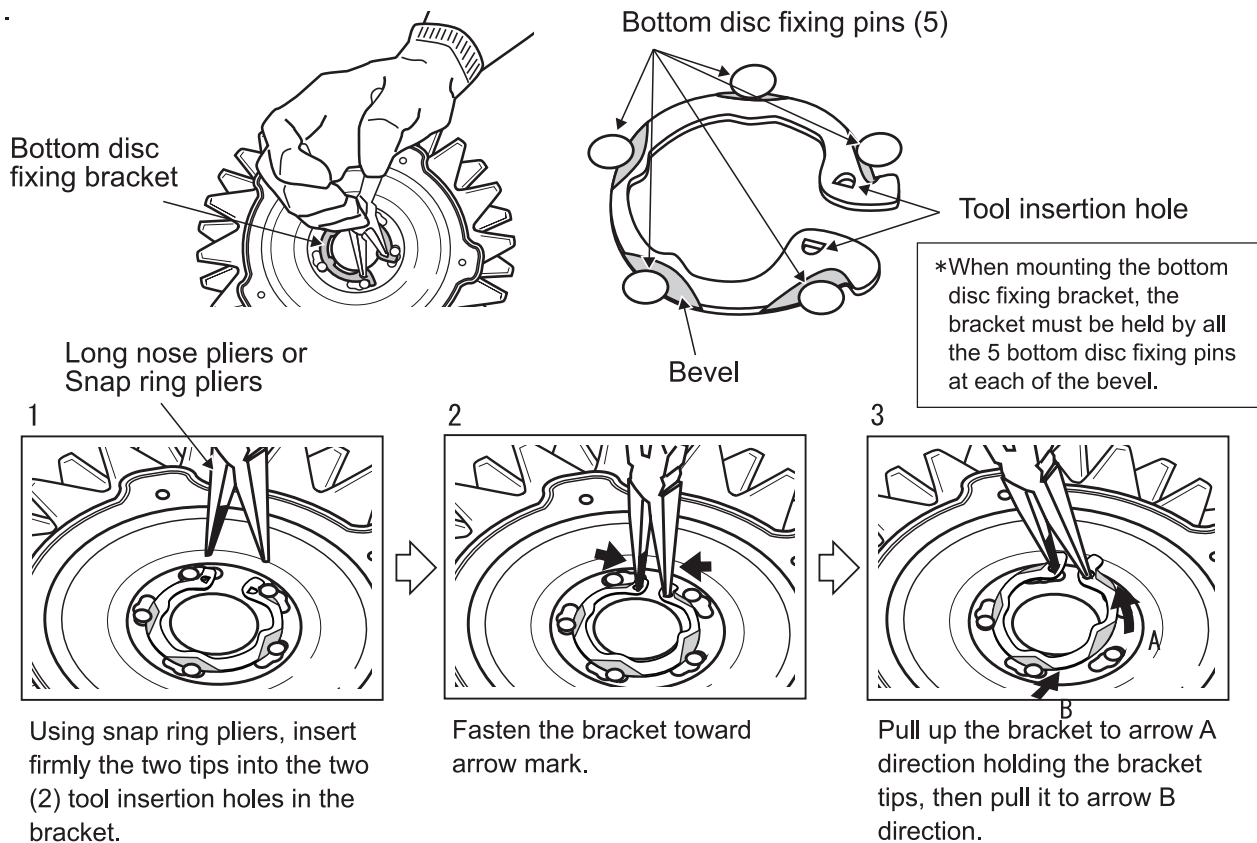

How to remove the bottom disc

- 2 . Turn the bottom disc either direction holding the main body until the fixing pin comes to the grooved larger hole.

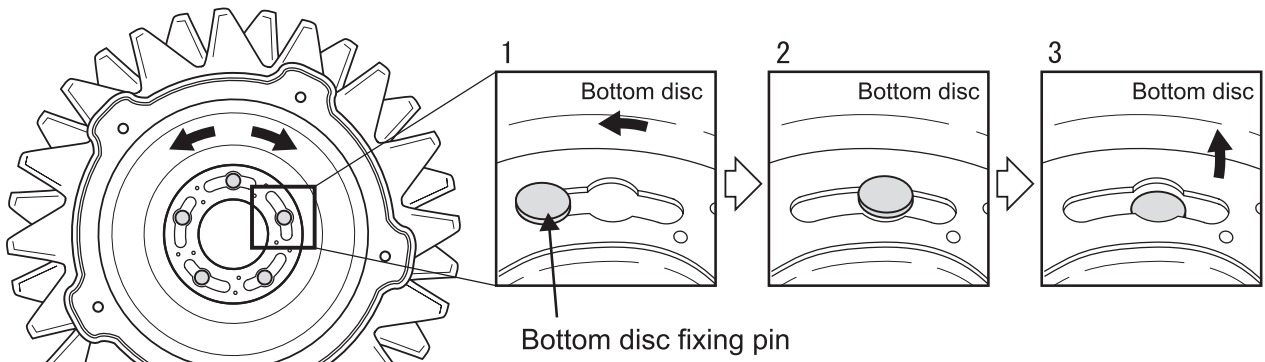

How to remove the upper and the lower blades

- 3 . Remove the upper and the lower blade turning for the arrow direction.

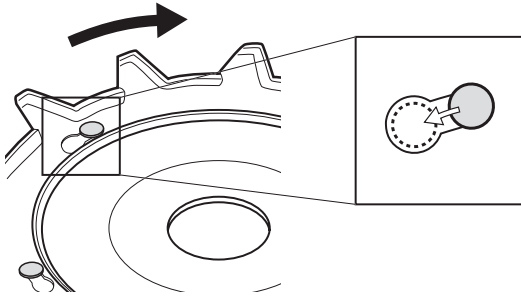

How to mount the bottom disc

- 4 . Mount the bottom disc turning CW direction as illustrated below then mount the bottom disc fixing bracket.

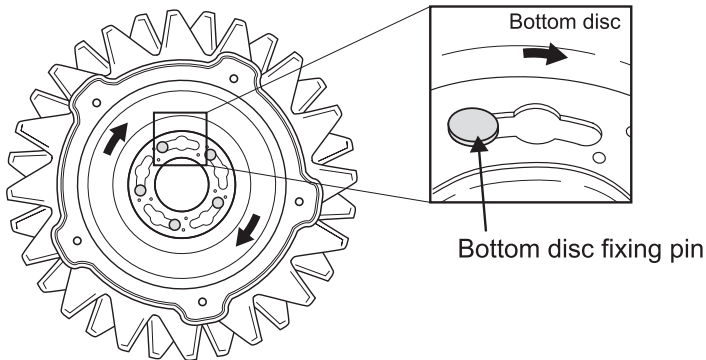

Turn the bottom disc holding the main body until the bottom disc fixing pin comes to the hole end, then mount the disc fixing bracket to ensure the disc fixation.

How to mount the bottom disc fixing bracket

- 5 . The bottom disc fixing pin is to be mounted as illustrated below. Use the long nose pliers mount it.
1. Remove the grasses and foreign substances if any adhering to the bottom disc or bottom disc fixing pin before the Bottom disc fixing bracket is mounted.
 2. The bottom disc fixing bracket must be mounted in a manner that it hangs to all of the five (5) the bottom disc fixation pins.

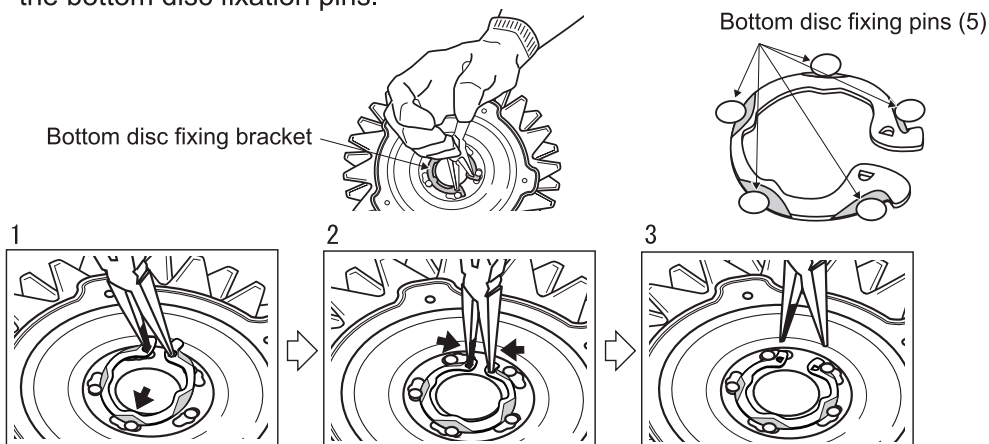

* Be careful not to jump out the bottom disc fixing bracket while mounting it.

Lower Blade

1. Clean the blades and bottom disc with a brush, to remove grass or dirt stuck to them.

See **Maintenance points** below for details.

2. Wipe the blades and bottom disc and dry them. Then, wipe them gently with an oily cloth. To install the blade, first position the blade holes on fixing pins, then turn the blade counterclockwise.

- Take care not to install the blade upside down.
- Make sure all the fixing pins are in place when the blade is installed.

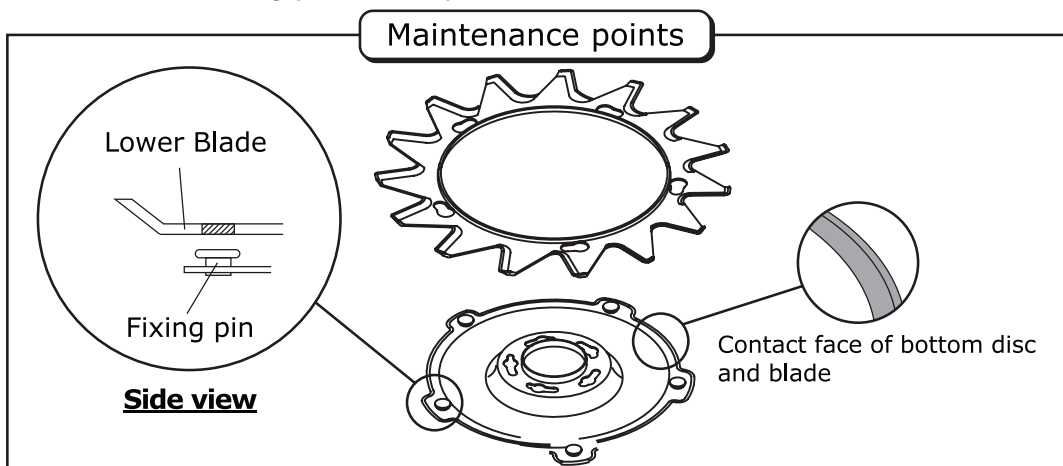

Upper Blade

1. Clean the blades and bottom disc with a brush, to remove grass or dirt stuck to them.

See **Maintenance points** below for more details

2. Wipe the blades and bottom disc, and dry them. Then, wipe them gently with an oily cloth.

3. Mount the blade by aligning the blade holes and fixing pins, then by turning the blade counterclockwise.

- Take care not to install the blade upside down.
- Make sure all the fixing pins are in place when the blade is installed.

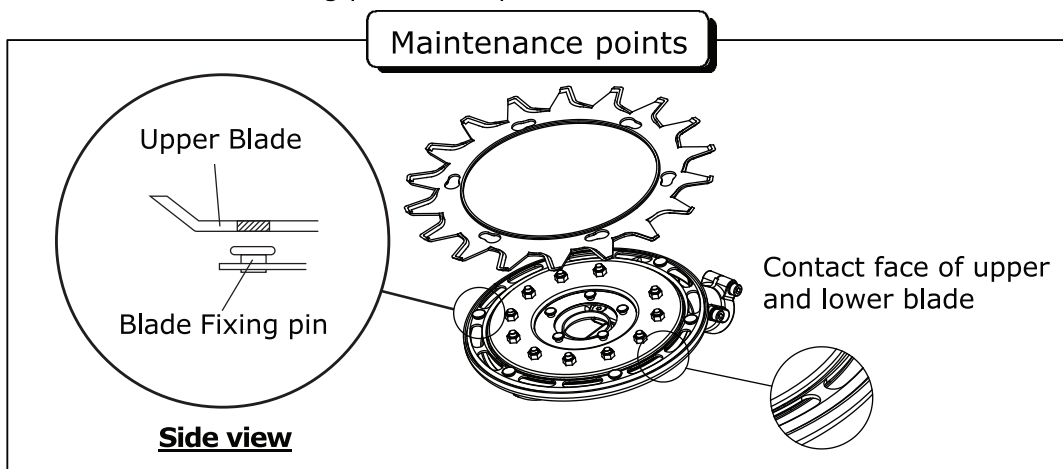

Lubrication

- 1 Remove the two screws to allow grease to be injected (see illustration), and inject grease into both screw holes. Inject about 20cc per every 10 hours of operation as a reference.

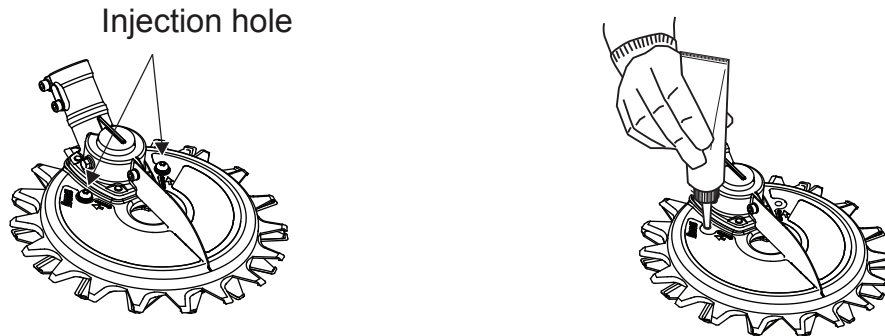

- 2 Insert the two screws and tighten securely.

Do not replace the screws with the grease nipple.
It may be loosened by vibration during use.
Make sure to use the genuine the washer built-in screw.

- 3 Remove hex screw (M5×6) in the gear case, and inject about 10cc of grease into the hole every 25 hours of operation as a reference.

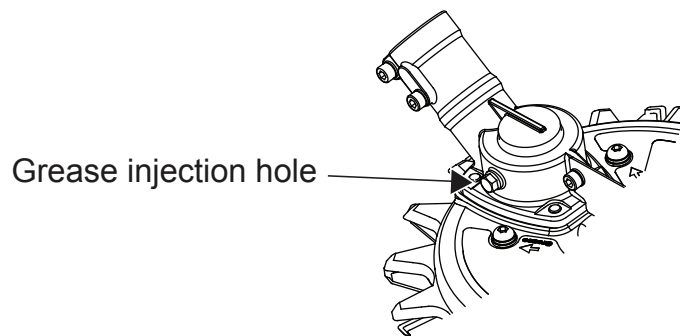

- 4 Insert the hex screw(M5×6) and tighten it securely.

This completes lubrication

* Lubricate the Power Rotary Scissors and oil the blades if it is to be stored for more than 30 days.

BLADE REPLACEMENT

WARNING

Make sure the engine is stopped before replacing the blades. Wear gloves to handle the blades.

*To replace the blade, exclusive long nose pliers or snap ring pliers is required.

See pages 8 through 10 for removal and installation of the blades.

1. Follow steps 1 through 3 of the maintenance section on pages 8 and 9.
2. Clean up the body with a brush to remove grass and dirt and wash it with water.
3. Wipe the body and dry it. Then wipe it with an oily cloth before installing the blades.
4. Turn the upper blade clockwise, holding the main body, until the fixing pin reaches the other end of the hole. Then, lift off the upper blade.
5. Clean up the body with a brush to remove grass and dirt and wash it with water.
6. Wipe the body and dry it. Then wipe it with an oily cloth before installing the blades.
7. Follow "Lower blade installation" on page 9.

Clean up main body and bottom disc before mounting new blade

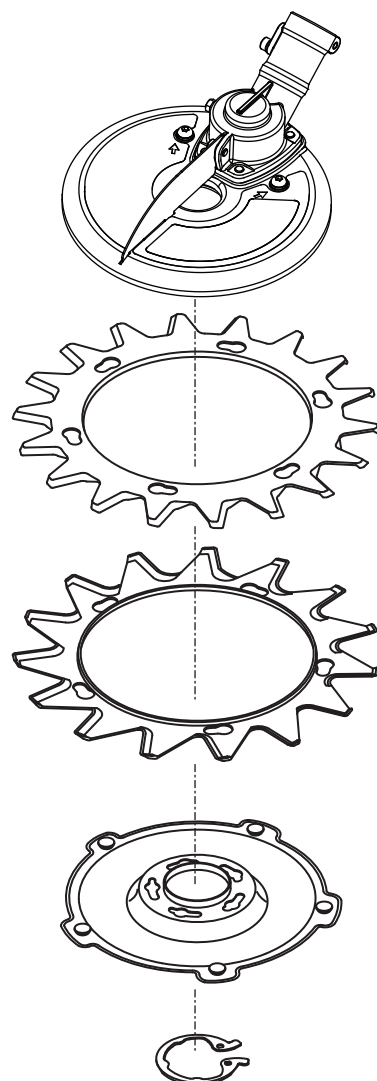

BLADE SHARPENING

Sharpen the blades when grass tends to stick to them.

WARNING

Stop the engine before sharpening the blades. Wear gloves to help prevent injury.

Blade sharpening

1. First remove the upper and lower blades.
(See pages 8 through 10 for removal and installation)
2. Sharpen the edge of the both upper and lower blades
(see illustration) with a file.
 - Take care not to heat the blade enough to change the color. This may decrease blade hardness.
 - Sharpen the blade edge at 45 degrees.

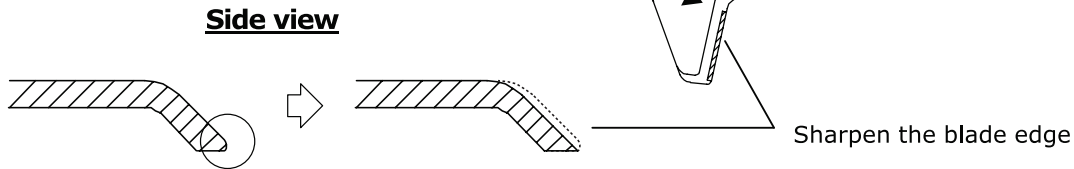

Timing for Blade Replacement and Blade Sharpening

1. It is suggested to sharpen the blades in every 8 to 10 hours of operation as a reference in case of cutting soft grasses or lawn.
2. It is also suggested to replace the blades in every 30 to 40 hours of operation including 3 to 4 times of blade sharpening.
3. Replace the blades if either upper or lower blade thickness has been worn to 2.7mm or less .
 - Referenced operating hours for blade sharpening differs depending on the type grasses, or cutting environments including obstacles like soil and sand.
 - Some grasses could be rolled up in the blades. If this happens, first remove the blades then remove completely the rolled grasses, as it could seriously affect the life of blades and main body.

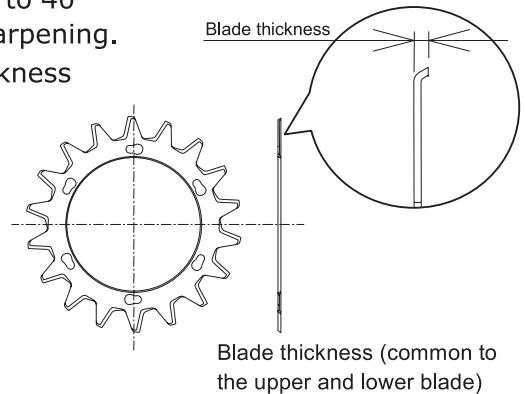

Specifications

Model	ASK-R23BMS
Cutting method	Rotary scissor blades
Dimensions L × W × H (mm)	258 × 230 × 101
Weight (kg)	1.7 (Including gear case)

Surface	Aluminum (A5052)	
Reduction	Planetary gear reduction	
Ratio	Upper	1:18.8
	Lower	1:13.5

WARNING

Stop the engine before handling the unit. Wear gloves to handle the blades.

Status	Where to check	Solution	See Page
Blade does not turn or does not turn properly	Is the brushcutter engine working?	Start the engine.	
	Is the unit properly mounted?	Mount the unit properly.	6
	Any cracks or bends on the blades?	Replace the blade or blades.	8 - 10
	Any foreign objects caught in the blades?	Remove the objects.	8
	Is the product properly lubricated?	Inject grease periodically.	11
	Does the brushcutter engine function properly?	Check all engine functions.	
Abnormal noise or Abnormal vibration	Any foreign objects caught in the blades?	Remove the objects.	8
	Any cracks or bends on the blades?	Replace the blade or blades.	8 - 10
	Are the upper and lower blade properly mounted?	Check the blade mounting.	8 - 10
	Is the product properly lubricated?	Inject grease periodically.	11
	Is the product properly mounted to the brushcutter?	Check the mounting.	6
	Is the brushcutter drive shaft bent?	Check the brushcutter .	
Dull blade cutting	Any foreign objects caught in the blades?	Remove the objects.	8
	Any cracks or bends on the blades?	Sharpen or replace the blade.	12 - 13
	Blade wear?	Sharpen the blade.	13
	Is the engine speed correct?	Adjust the engine speed properly.	7

Memo



MARUYAMA MFG. CO., INC.

4-15 UCHI-KANDA 3-CHOME, CHIYODA-KU

TOKYO 101-0047 JAPAN

Telephone: 81-3-3252-2285

Facsimile: 81-3-3252-2253

WEB : <http://www.maruyama.co.jp>